

BN00

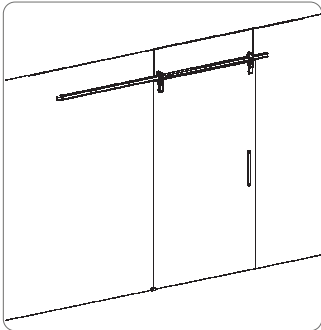

- Kit scorrevole Neus ad un anta - fissaggio su vetro .
- Kit "Neuscorre" para una puerta - fijación en el vidrio.
- One-leaf Neus sliding door kit - glass mount.
- Set Schiebetüren Neus mit einem Flügel - Befestigung am Glas.



Compreso

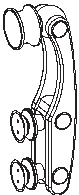

2X
BN10



2X
BN20



2X
BN30



1X
BN50



2X
BN60



6X
BN70

Included

Non compreso

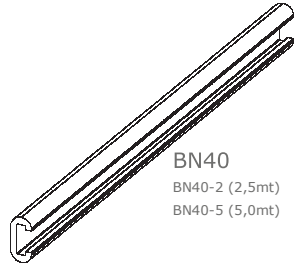

BN40
BN40-2 (2,5mt)
BN40-5 (5,0mt)

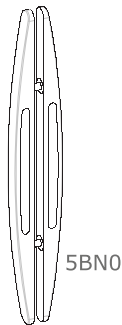

5BN0

Not included

BN01

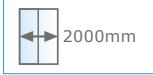

- Kit scorrevole Neus a due ante -fissaggio su vetro.
- Kit "Neuscorre" para dos puertas - fijación en el vidrio.
- Two-leaves Neus sliding door kit - glass mount.
- Set Schiebetüren Neus mit zwei Flügeln - Befestigung am Glas.

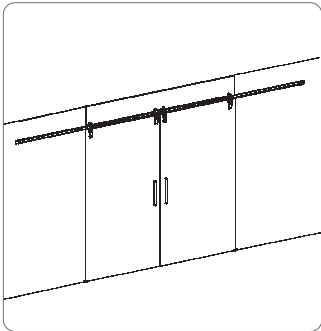

Compreso

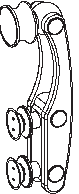

4X
BN10



4X
BN20



4X
BN30



2X
BN50



2X
BN60



9X
BN70

Included

Non compreso

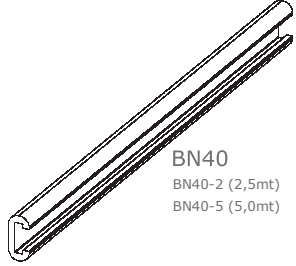

BN40
BN40-2 (2,5mt)
BN40-5 (5,0mt)



5BN0

Not included

BN05



- Kit scorrevole Neus ad un anta -fissaggio su muro.
- Kit "Neuscorre" para una puerta - fijación en la pared.
- One-leaf Neus sliding door kit - wall mount.
- Set Schiebetüren Neus mit einem Flügel - Befestigung an der Wand.

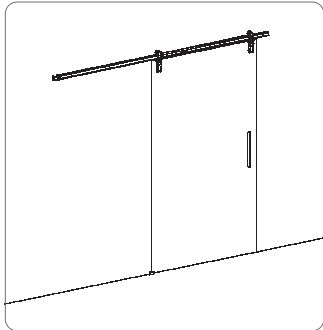

Compreso

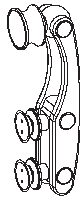

2X
BN10



2X
BN20



2X
BN30



1X
BN50



2X
BN60



3X
BN80

Included

Non compreso

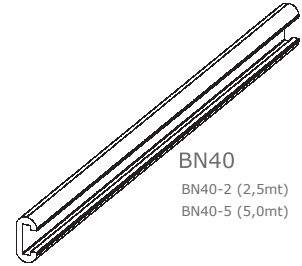

BN40
BN40-2 (2,5mt)
BN40-5 (5,0mt)

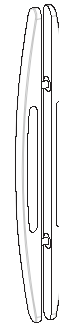

5BN0

Not included

BN06



- Kit scorrevole Neus a due ante -fissaggio su muro.
- Kit "Neuscorre" para dos puertas - fijación en la pared.
- Two-leaves Neus sliding door kit - wall mount.
- Set Schiebetüren Neus mit zwei Flügeln - Befestigung an der Wand.

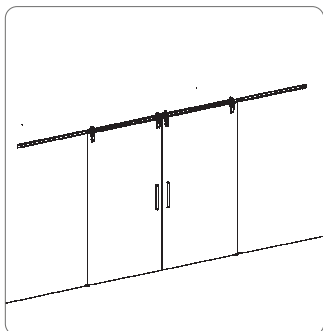

Compreso

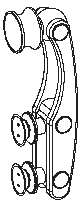

4X
BN10



4X
BN20



4X
BN30



2X
BN50



2X
BN60



5X
BN80

Included

Non compreso

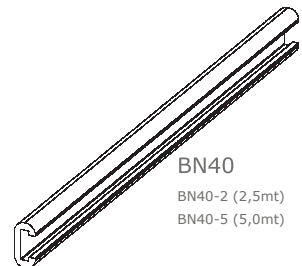

BN40
BN40-2 (2,5mt)
BN40-5 (5,0mt)

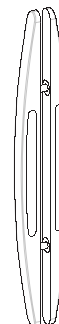

5BN0

Not included

BN00

Neuscorre

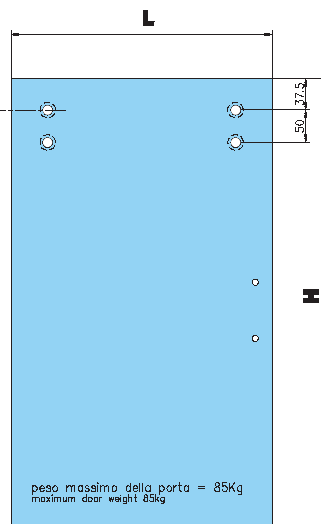
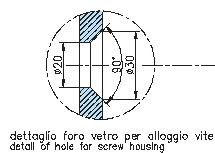
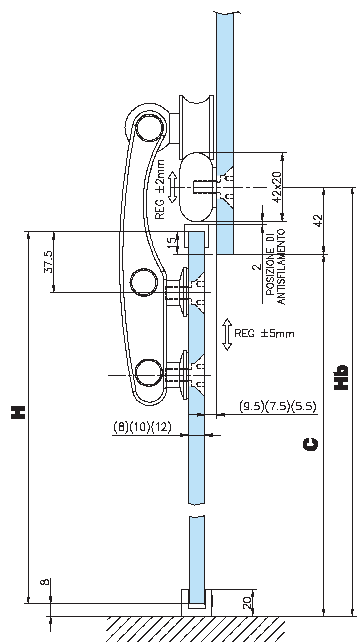
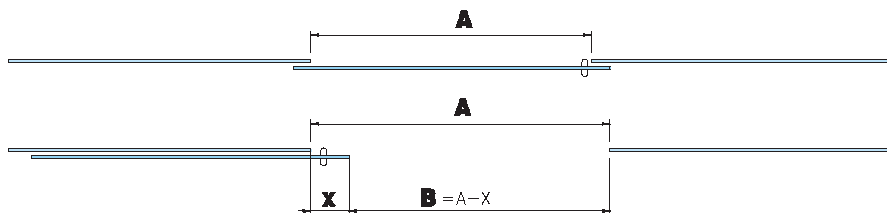
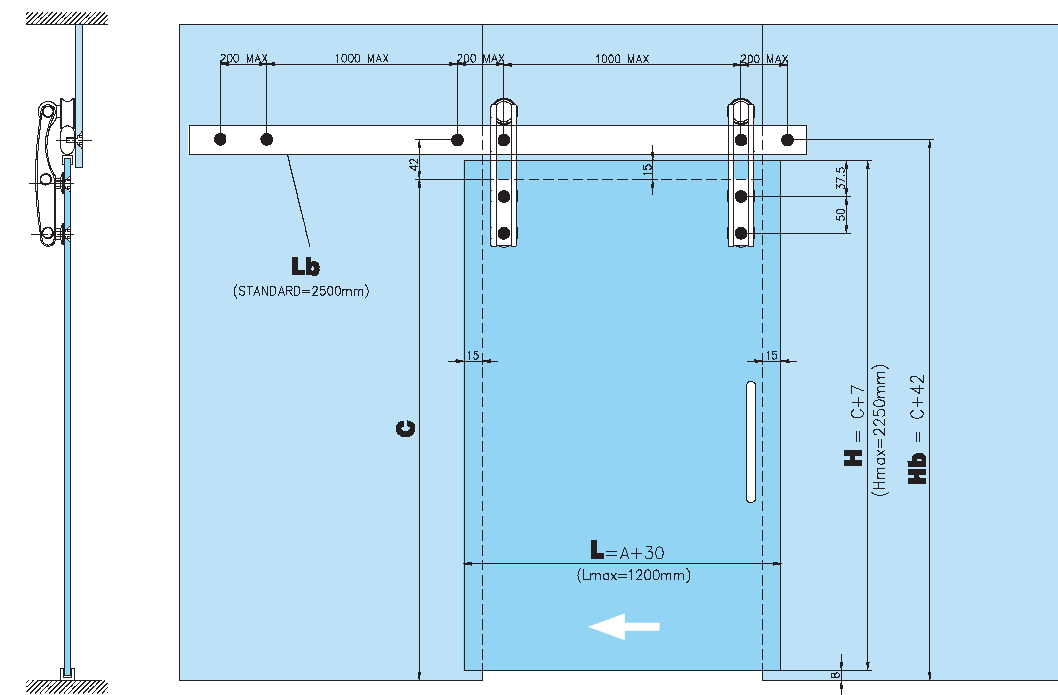

peso massima della porta = 85Kg
maximum door weight 85kg

BN01

Neuscorre

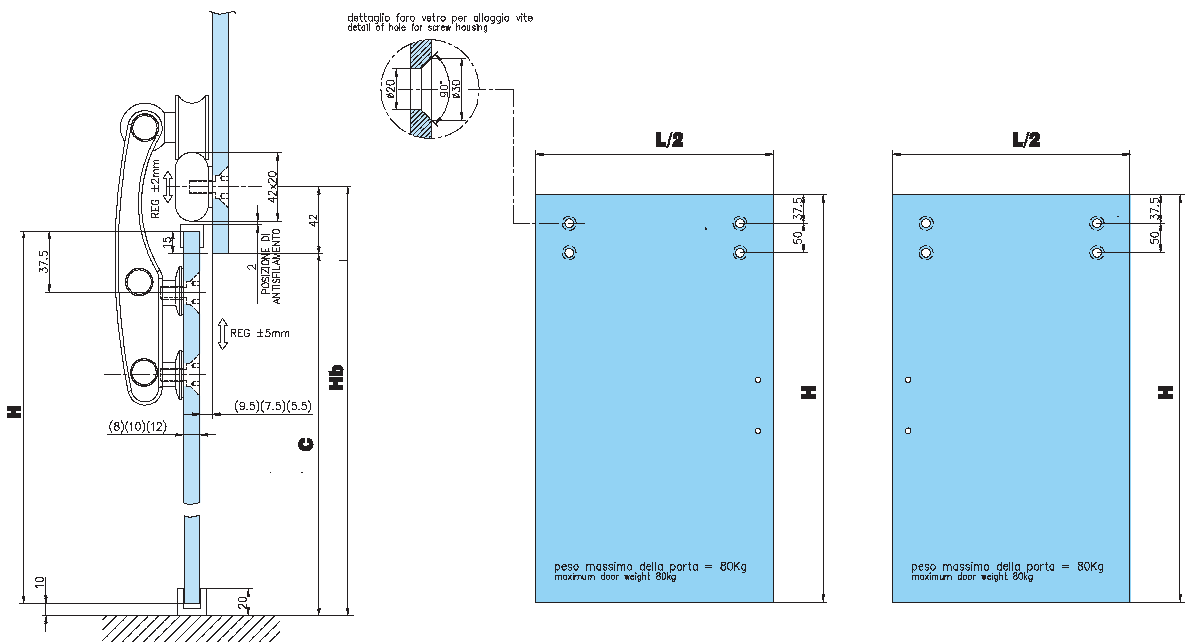
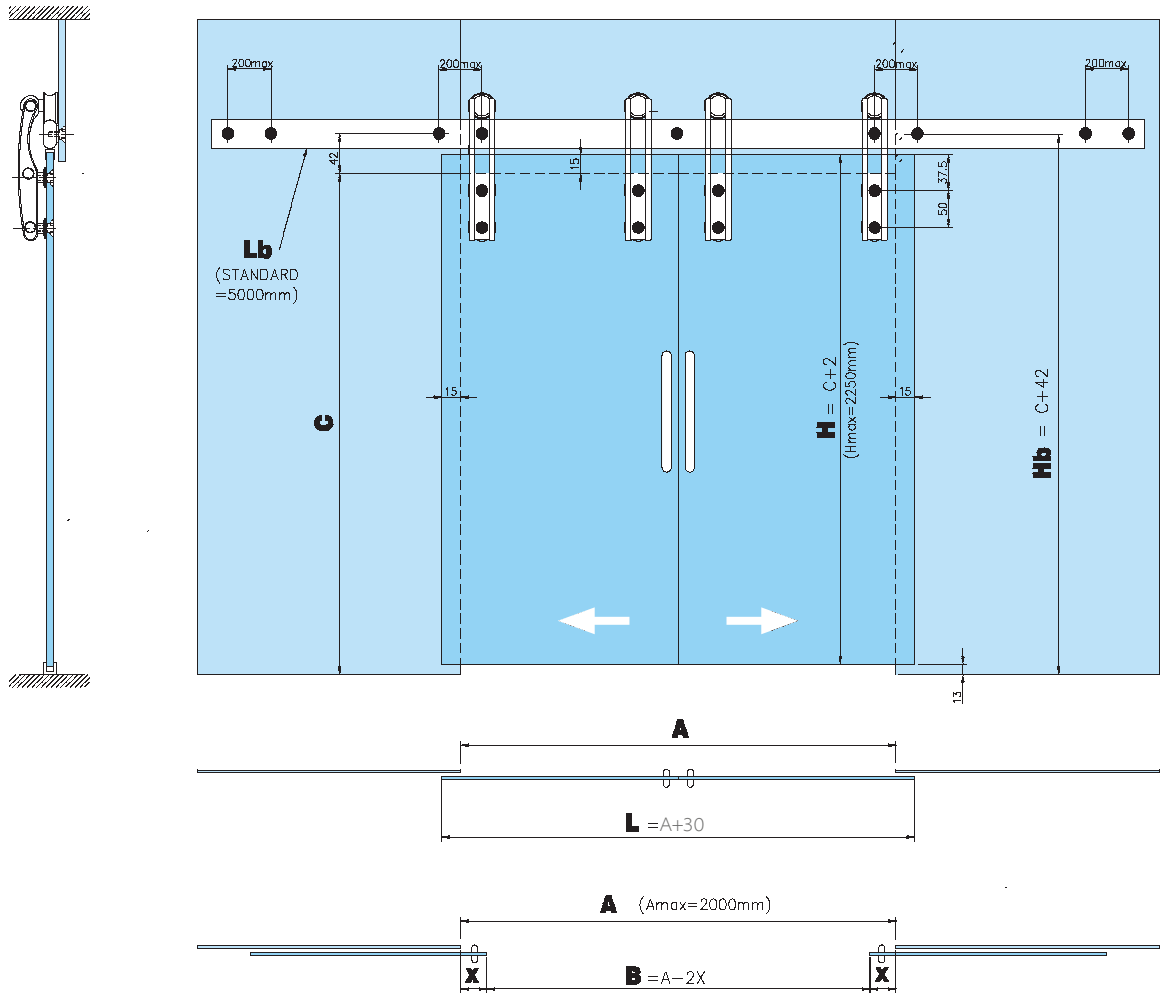

ATTENZIONE: Il fissaggio del sopraluce al soffitto, così come l'installazione dell'intera struttura, sono comunque ad esclusiva cura e responsabilità dell'installatore.
 ¡ CUIDADO ! El ajuste de la luna al techo, así como la instalación de la estructura, son responsabilidad del instalador.
 ATTENTION: The transom's fixing on the ceiling and the installation of the entire structure are in any case at exclusive care and responsibility of the installer.
 ACHTUNG: Die Feststellung des Oberlichtfensters an der Decke und die Montage der ganzen Strukturs sind auf jedem Fall exklusive Pflege und Verantwortlichkeit des Monteurs.

Sistema Neuscorre - Sistema Neuscorre system - Neuscorre system - Neuscorre System

BN05

SOLUZIONE A MURO FRONTALE
FRONTAL WALL SOLUTION

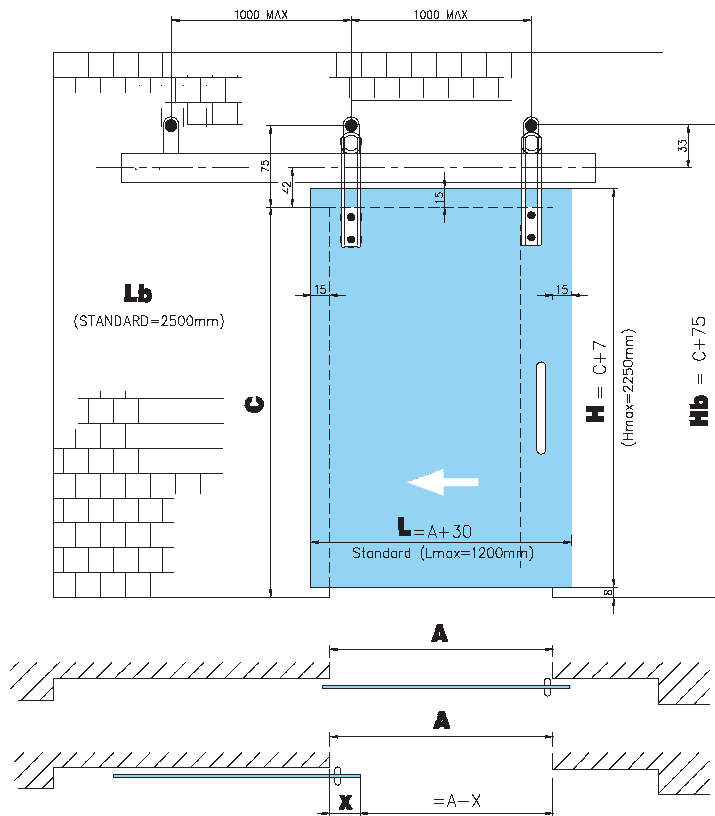
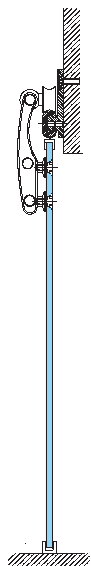

BN90 (optional)

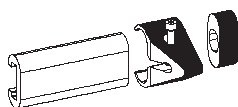

IL FISSAGGIO A MURO AVVIENE UTILIZZANDO
ADEGUATI TASSELLI AD ESPANSIONE
the wall fixing is made
using appropriate screw anchor

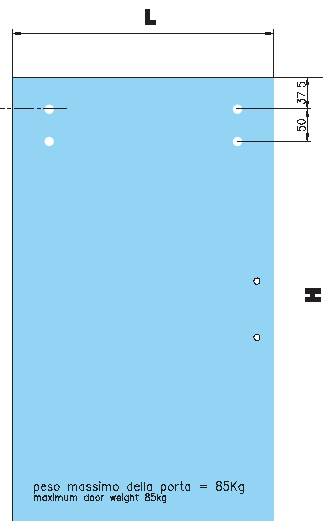
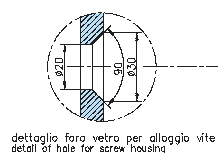
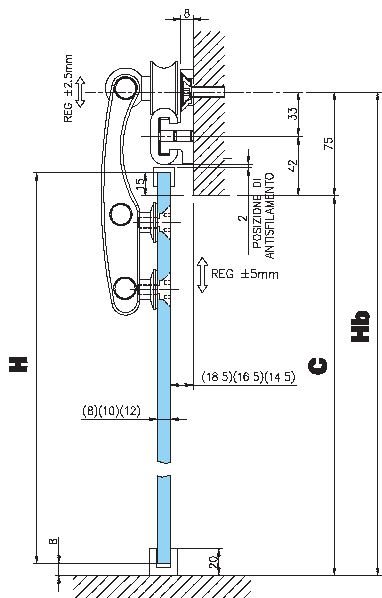
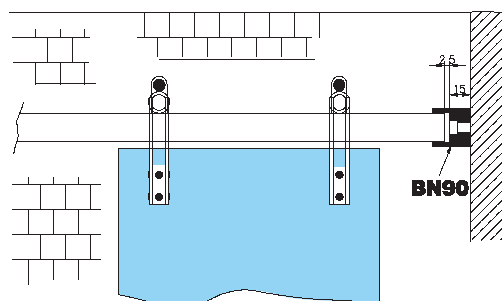

BN06

Neuscorre

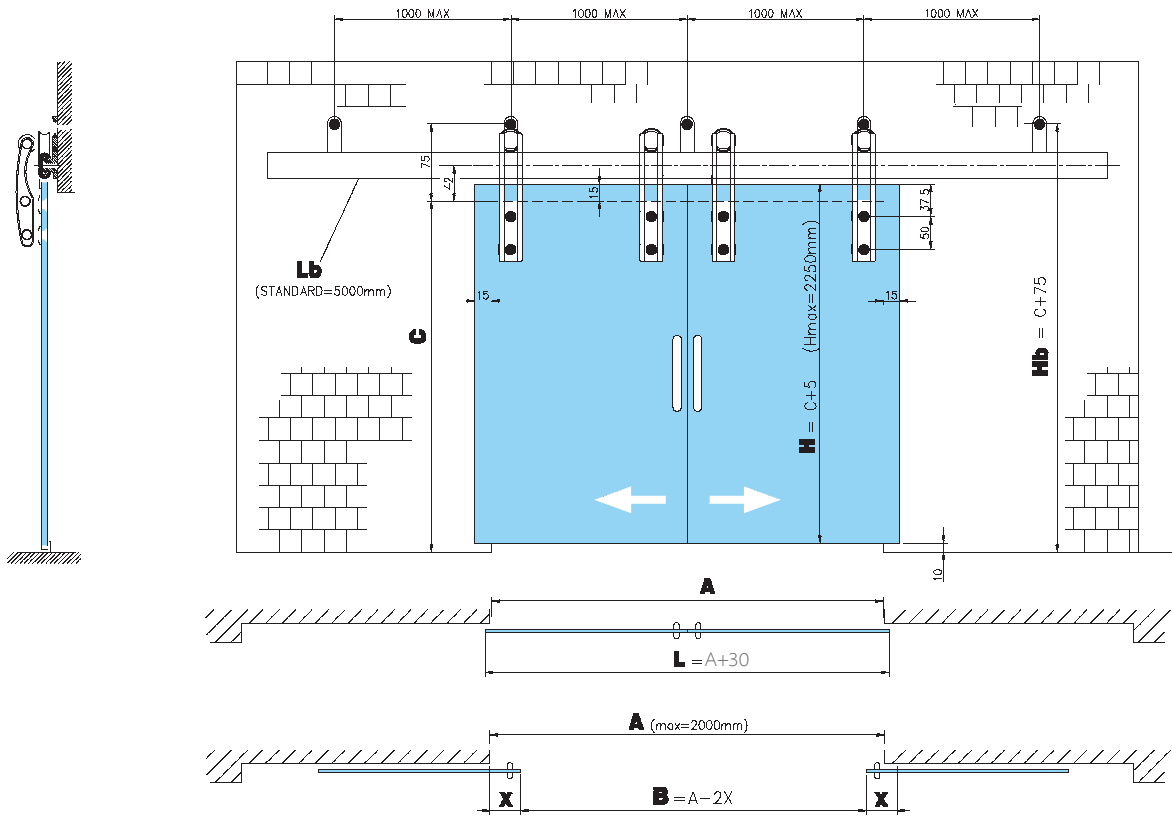

BN90 (optional)

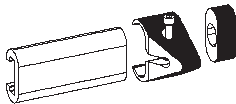

IL FISSAGGIO A MURO AVVIENE UTILIZZANDO ADEGUATI TASSELI AD ESPANSIONE
the wall fixing is made using appropriate screw anchor

dettaglio foro vetro per alloggiamento vite
detail of hole for screw housing

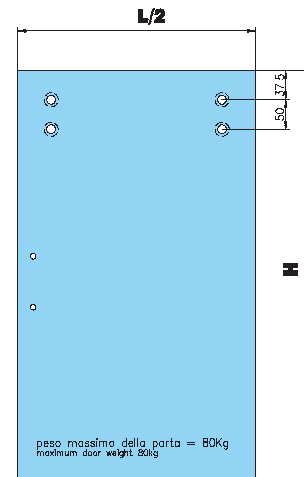
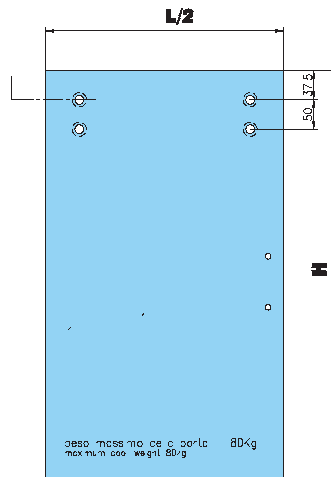
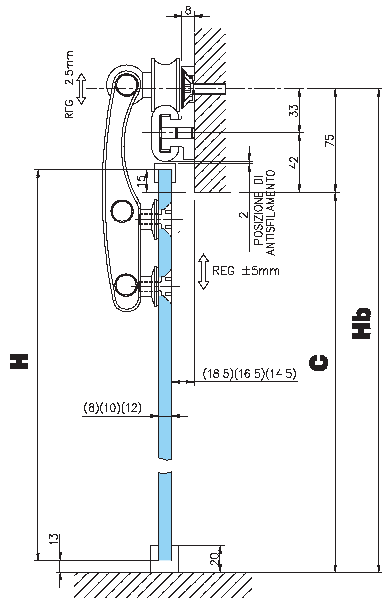
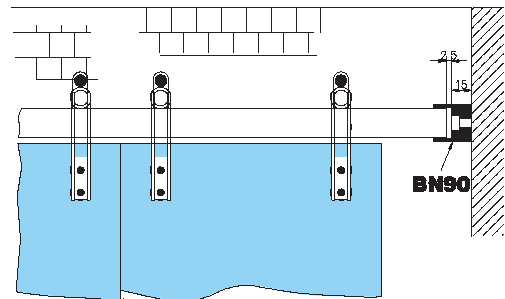
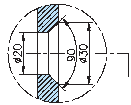

Slak SYSTEM

- Kit scorrevole "Slak" ad un anta -fissaggio su muro.
- Kit "Slak" para una puerta - fijación en la pared.
- One-leaf "Slak" sliding door kit - wall mount.
- Set Schiebetüren "Slak" mit einem Flügel - Befestigung an der Wand.

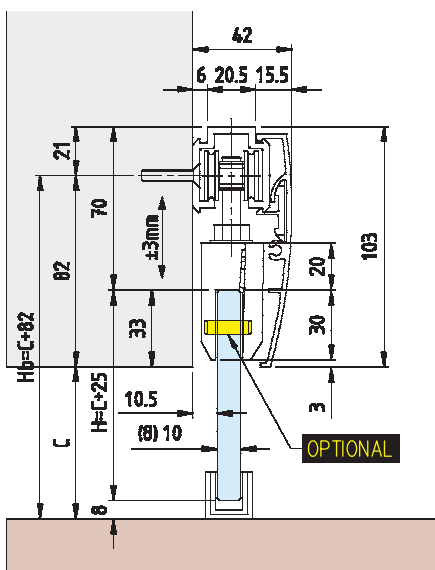
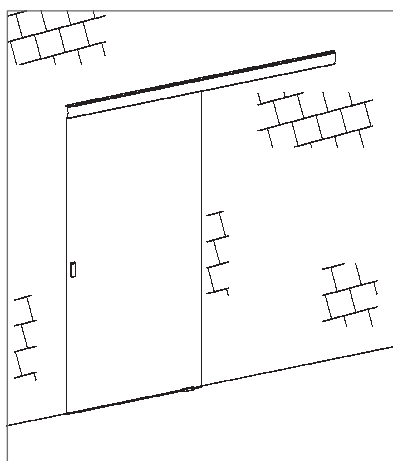

OPTIONAL

8mm
10mm

Foro vetro Ø 10
Hoje en el vidrio Ø 10
Glass hole Ø 10
Glasbohrung Ø 10

1 x BS00

B905

BS10

BS30

BN50



1 x BS40

1 x BS45

1 x BS60

1000mm

MAX 75kg

B905 + BS10 STANDARD

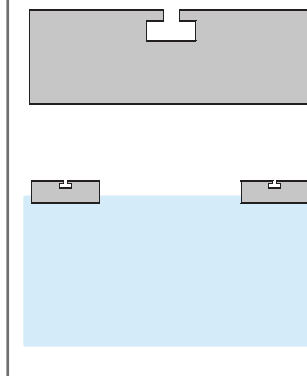

1000 ÷ 1200mm

MAX 120kg

B905 + BS10 + OPTIONALS

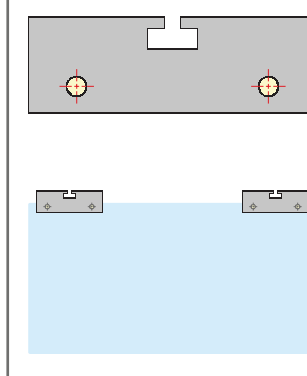

>1200mm

MAX >120kg

+N B905 + BS10 + OPTIONALS

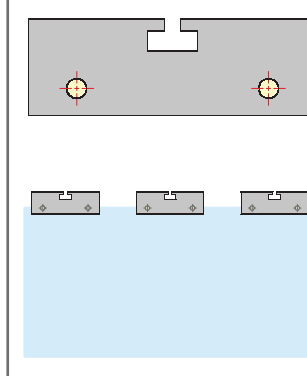

Slak SYSTEM

- Kit scorrevole "Slak" a due ante - fissaggio su muro.
- Kit "Slak" para dos puertas - fijación en la pared.
- Two-leaves "Slak" sliding doors kit - wall mount.
- Set Schiebetüren "Slak" mit zwei Flügeln - Befestigung an der Wand.

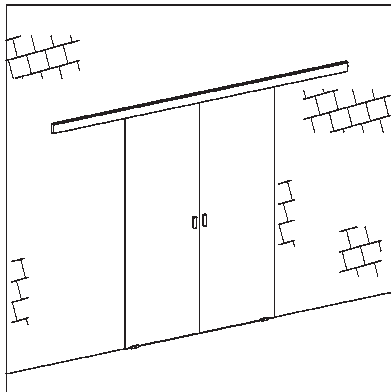

OPTIONAL
Foro vetro Ø 10
Hoje en el vidrio Ø 10
Glass hole Ø 10
Glasbohrung Ø 10

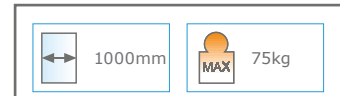
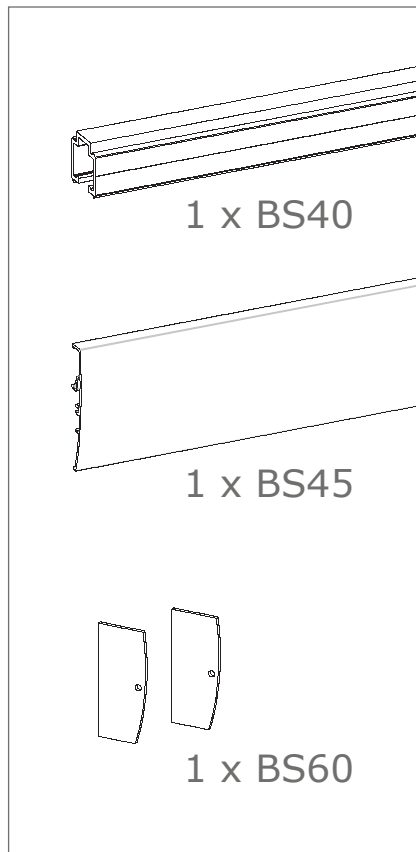
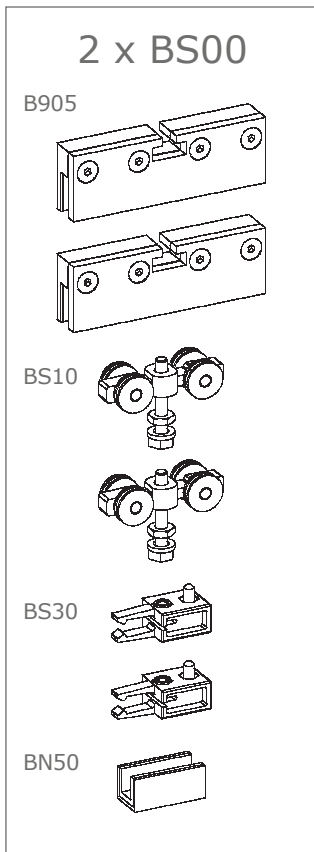
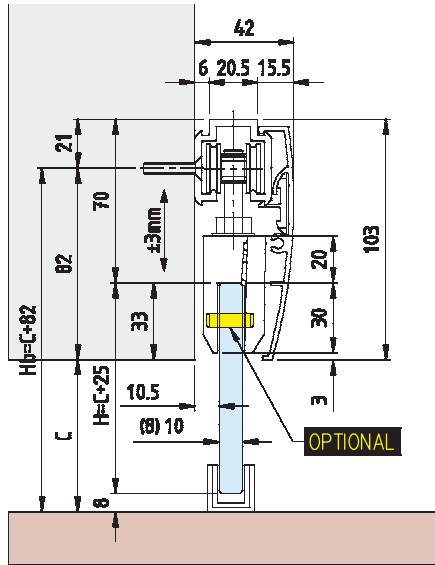

**B905 + BS10
STANDARD**

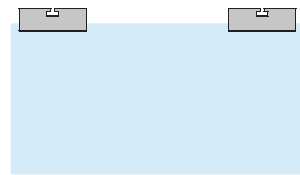
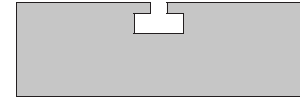

**B905 + BS10
+ OPTIONALS**

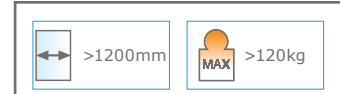
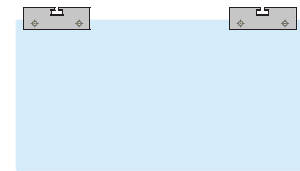
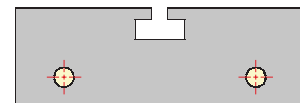

**+N B905 + BS10
+ OPTIONALS**

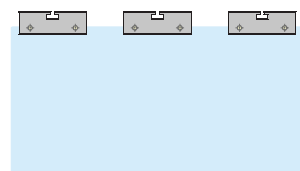
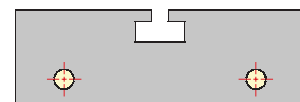

Slak SYSTEM

- Kit scorrevole "Slak" ad un anta -fissaggio su muro + fisso in vetro.
- Kit "Slak" para una puerta - fijación en la pared y vidrio fijo.
- One-leaf "Slak" sliding door kit – wall mount + one fixed glass.
- Set Schiebetüren "Slak" mit einem Flügel - Befestigung an der Wand + einen Sitenteil.

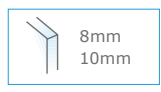
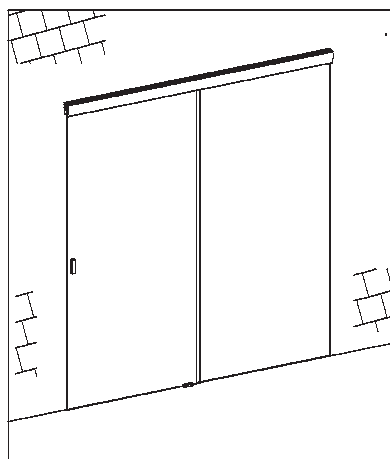

OPTIONAL
 Foro vetro Ø 10
 Hoje en el vidrio Ø 10
 Glass hole Ø 10
 Glasbohrung Ø 10

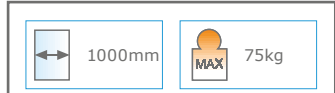
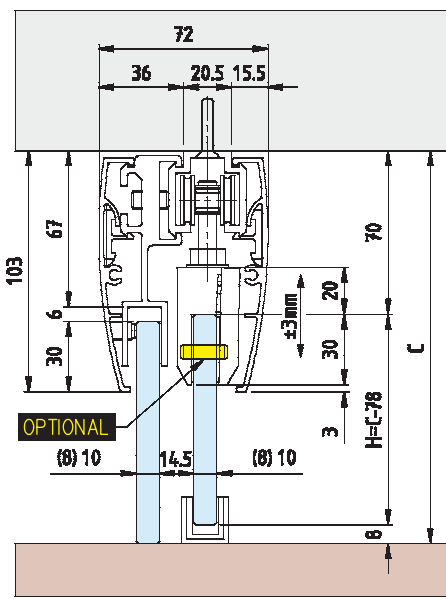

B905 + BS10 STANDARD

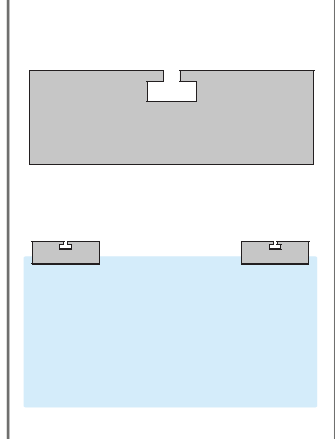

B905 + BS10 + OPTIONALS

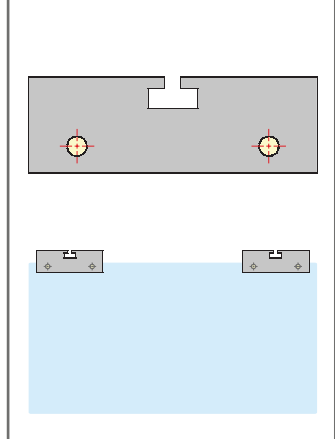

+N B905 + BS10 + OPTIONALS

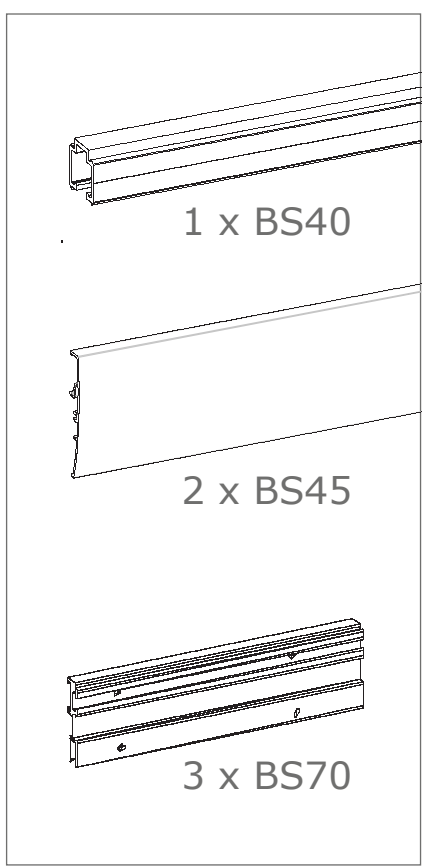
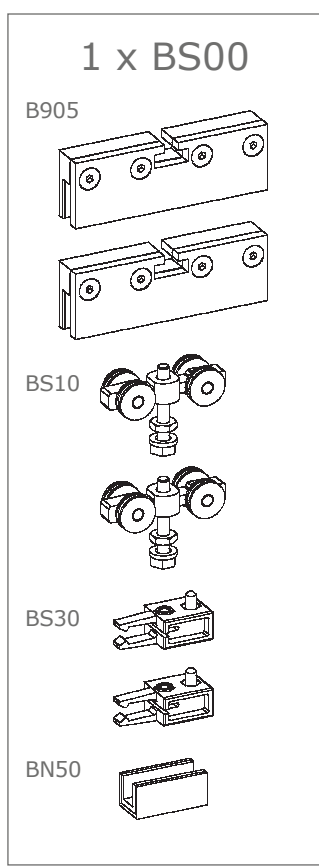
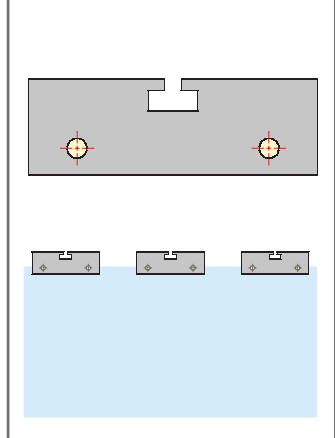

Sistema Slak - Sistema Slak - Slak system - Slak System

Slak SYSTEM

- Kit scorrevole "Slak" a due ante - fissaggio su muro + 2 fissi in vetro.
- Kit "Slak" para una puerta - fijación en la pared y dos fijos en vidrio.
- Two-leaves "Slak" sliding door kit - wall mount + 2 fixed glasses.
- Set Schiebetüren "Slak" mit zwei Flügeln - Befestigung an der Wand + 2 Seitenteile.

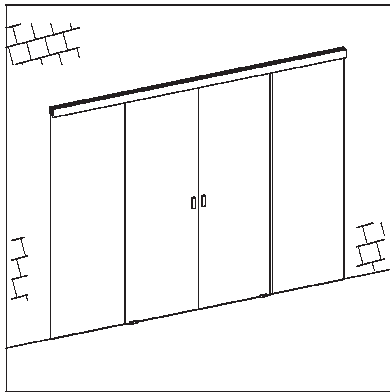

OPTIONAL
Foro vetro Ø 10
Hoje en el vidrio Ø 10
Glass hole Ø 10
Glasbohrung Ø 10

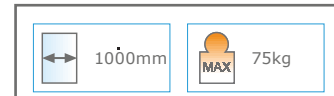
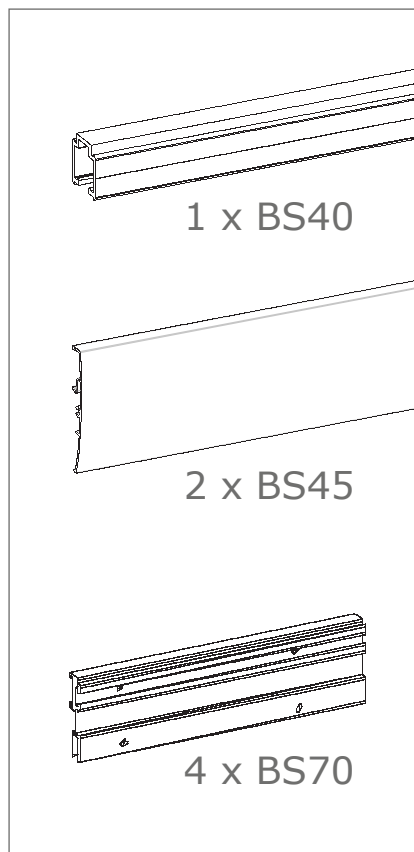
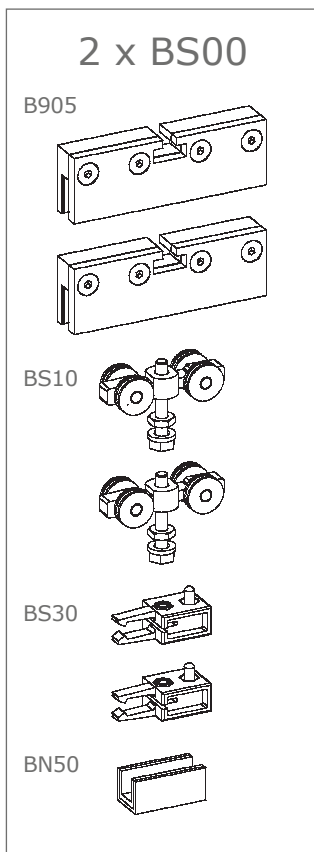
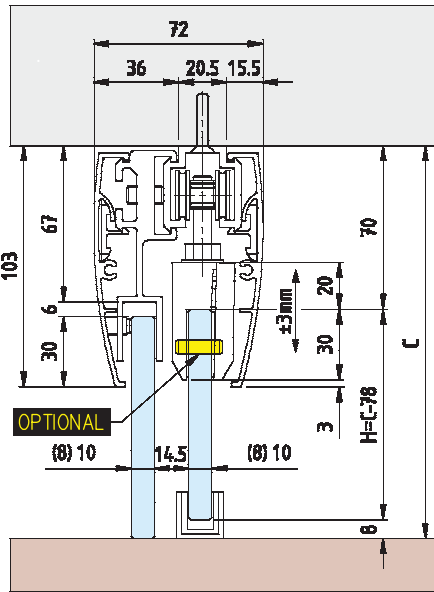

**B905 + BS10
STANDARD**

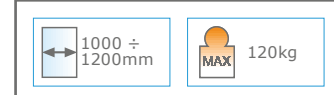
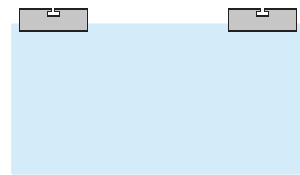
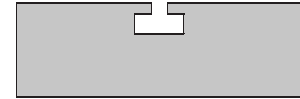

**B905 + BS10
+ OPTIONALS**

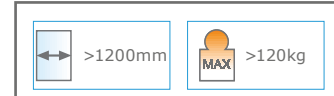
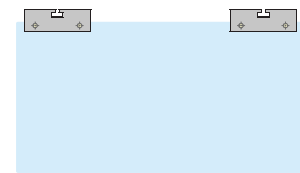
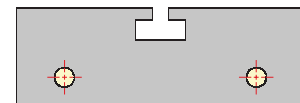

**+N B905 + BS10
+ OPTIONALS**

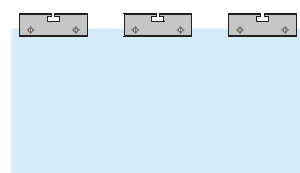
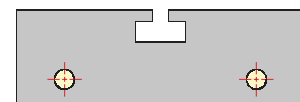

BS40

- Binario Slak L = 2/3/5 mt.
- Vía "Slak" L = 2/3/5 mt.
- Slak rail L = 2/3/5 mt.
- Schiene Slak L = 2/3/5 mt.

Il binario ha una foratura con passo standard. In caso di taglio potrebbe essere necessario eseguire una foratura ad hoc.

La vía tiene un agujero de "paso" estándar. Cuando corte, deba ejecutar una perforación especial.

The rail has holes with standard spacing. In case of cut, it could be necessary to realize holes ad hoc.

Die Schiene hat Bohrung mit Standardstand. Im Fall von Schnitt könnte es notwendig sein, eine Bohrung ad hoc zu realisieren.

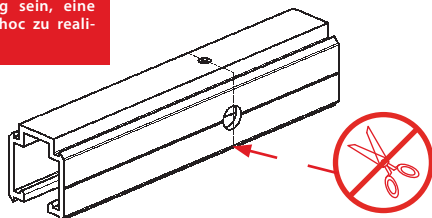
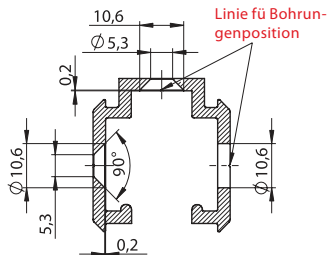

Evitare di accorciare la barra in prossimità dei fori - No acorte la barra cerca de los agujeros. - Avoid to make the bar shorter near the holes - Die Schiene in der Nähe der Bohrungen nicht abkürzen.

BS45

- Veletta Slak L = 2/3/5 mt.
- Charter "Slak" L = 2/3/5 mt.
- Slak spandrel panel L = 2/3/5 mt.
- Anlauf Slak L = 2/3/5 mt.

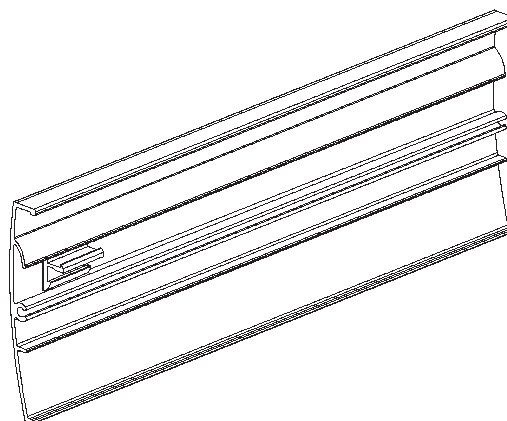
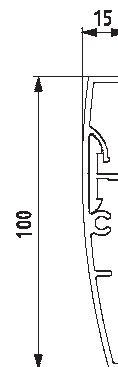

BS60

- Coppia tappi laterali Slak.
- Pareja de tapas laterales Slak.
- Slak double covers.
- Paar Deckel Slak.

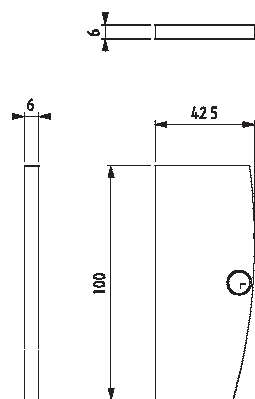

BS61

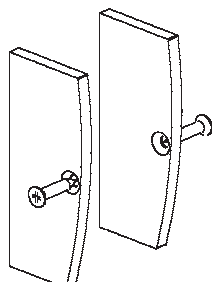
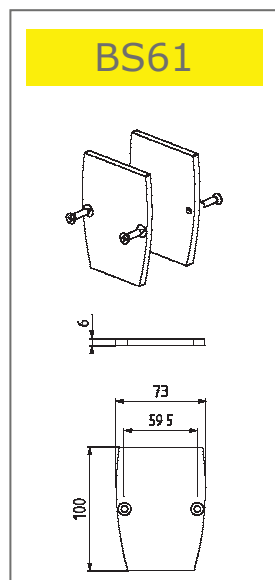

BS70

- Supporto fisso Slak L = 300 mm .
- Soporte Slak de fijo de L = 300 mm .
- Slak fixed support L = 300 mm .
- Schiene für feste Gehäuse L = 300 mm .

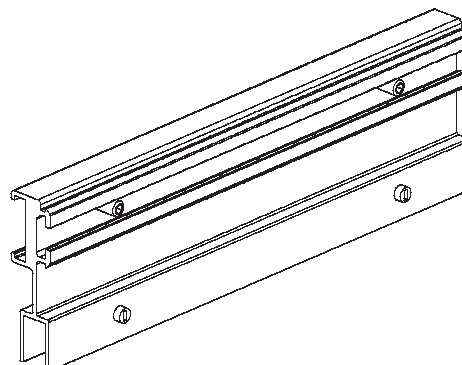
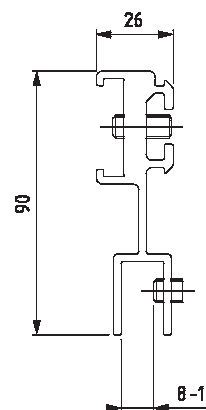

Slak-2 SYSTEM

- Kit scorrevole "Slak-2" ad un anta -fissaggio su muro.
- Kit "Slak-2" para una puerta - fijación en la pared.
- One-leaf "Slak-2" sliding door kit – wall mount.
- Set Schiebetüren "Slak-2" mit einem Flügel - Befestigung an der Wand.

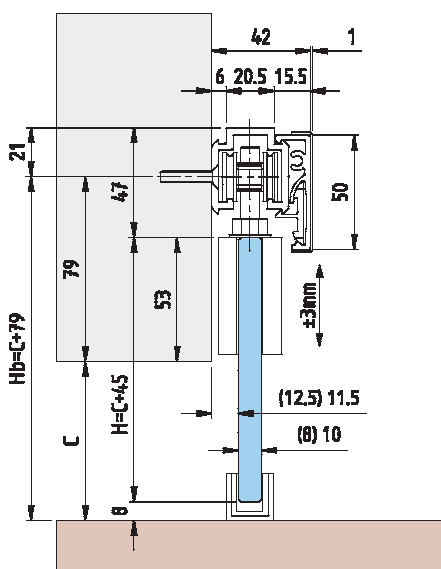
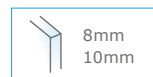
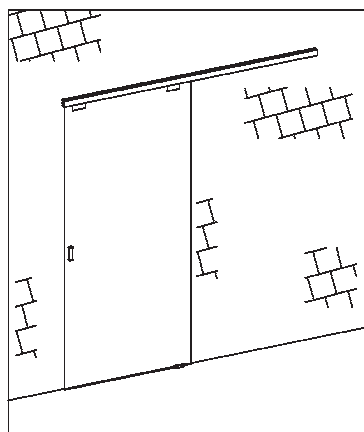

**B925
STANDARD**

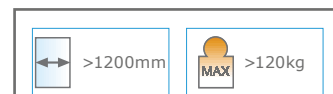
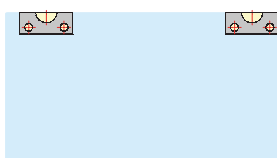
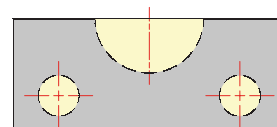

**B925
STANDARD**

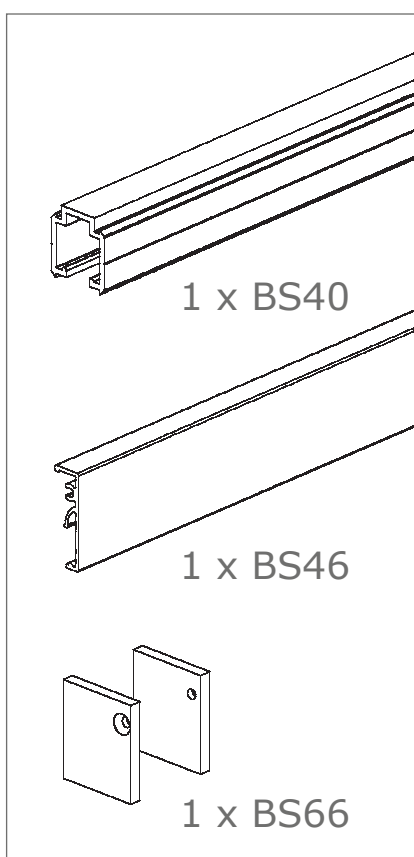
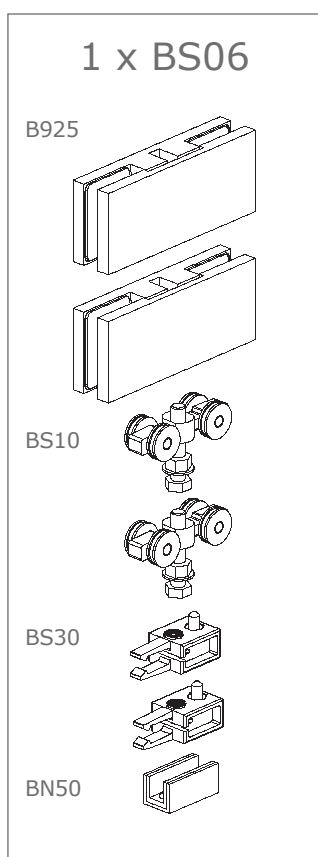
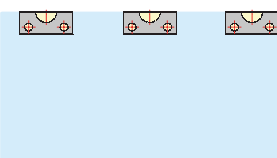
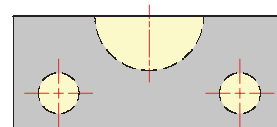

Slak-2 SYSTEM

- Kit scorrevole "Slak-2" a due ante - fissaggio su muro.
- Kit "Slak-2" para dos puertas - fijación en la pared.
- Two-leaves "Slak-2" sliding doors kit - wall mount.
- Set Schiebetüren "Slak-2" mit zwei Flügeln - Befestigung an der Wand.

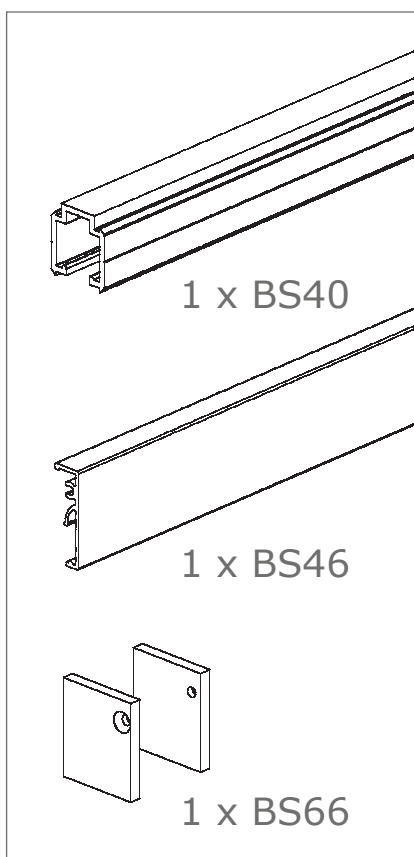
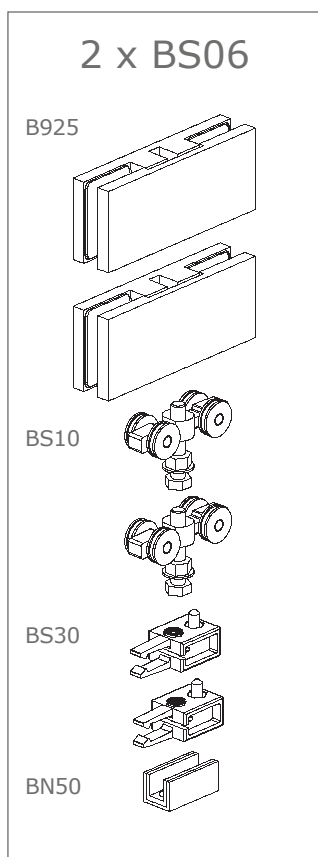
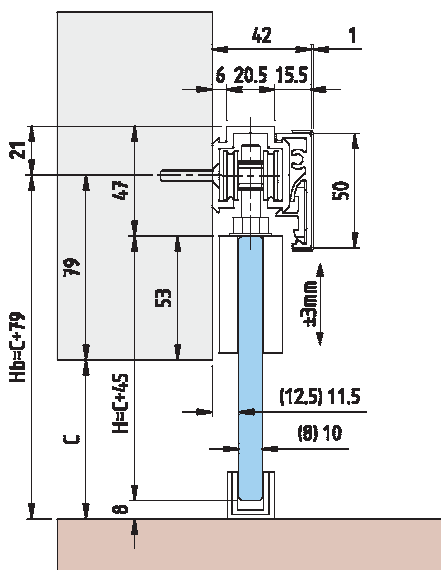
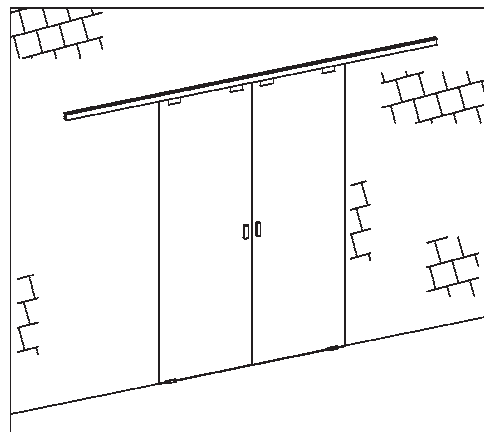

**B925
STANDARD**

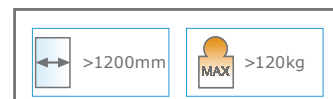
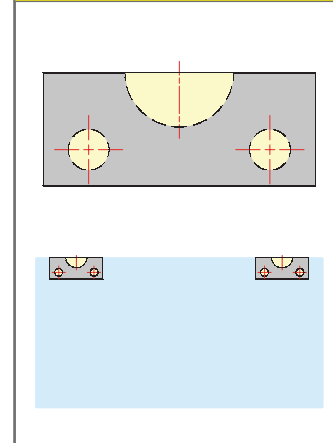

**B925
STANDARD**

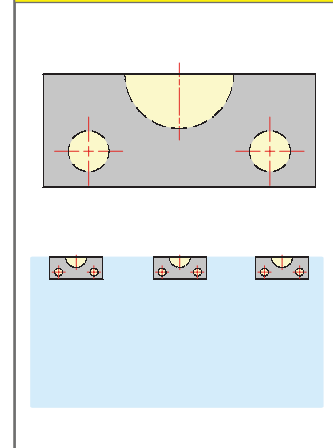

Sistema Slak-2 - Sistema Slak-2 - Slak-2 system - Slak-2 System

BS40

- Binario Slak-2 L = 2/3/5 mt.
- Vía "Slak-2" L = 2/3/5 mt.
- Slak-2 rail L = 2/3/5 mt.
- Schiene Slak-2 L = 2/3/5 mt.

Il binario ha una foratura con passo standard. In caso di taglio potrebbe essere necessario eseguire una foratura ad hoc.

La vía tiene un agujero de "paso" estándar. Cuando corte, deba ejecutar una perforación especial.

The rail has holes with standard spacing. In case of cut, it could be necessary to realize holes ad hoc.

Die Schiene hat Bohrung mit Standardstand. Im Fall von Schnitt könnte es notwendig sein, eine Bohrung ad hoc zu realisieren.

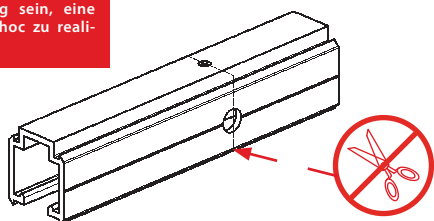
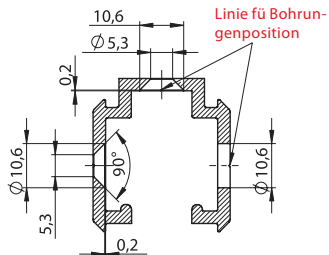

Evitare di accorciare la barra in prossimità dei fori - No acorte la barra cerca de los agujeros. - Avoid to make the bar shorter near the holes - Die Schiene in der Nähe der Bohrungen nicht abkürzen.

BS46

- Veletta Slak-2 L = 2/3/5 mt.
- Cárter "Slak-2" L = 2/3/5 mt.
- Slak-2 spandrel panel L = 2/3/5 mt.
- Anlauf Slak-2. L = 2/3/5 mt.

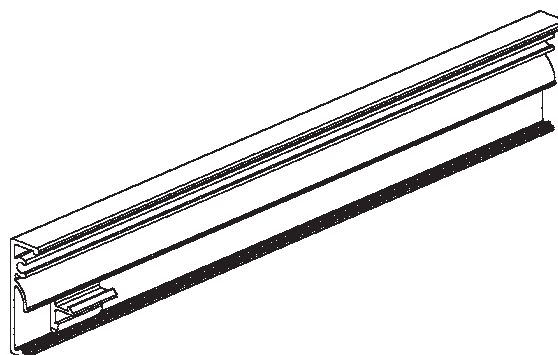
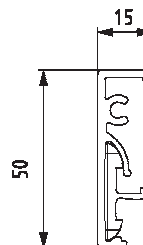

BS66

- Coppia tappi laterali Slak-2.
- Pareja de tapas laterales Slak-2.
- Slak-2 double covers.
- Paar Deckel Slak-2.

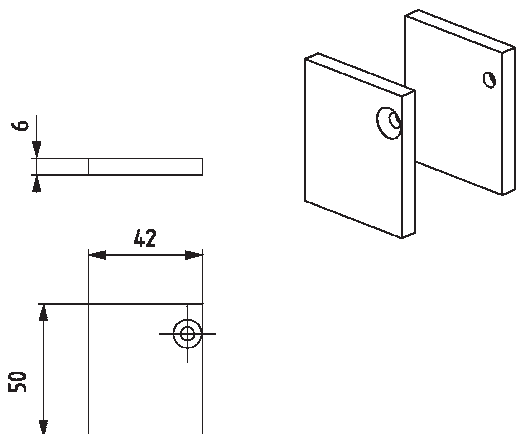

BS46 C

- Copriveletta per Slak-2 in acciaio inox L= 2,5 mt.
- Cobre charter para Slak-2 en acero. L= 2,5 mt.
- Stainless steel spandrel panel cover for Slak-2 L = 2,5 mt
- Anlaufabdeckung aus Edelstahl für Slak-2 L = 2,5 mt

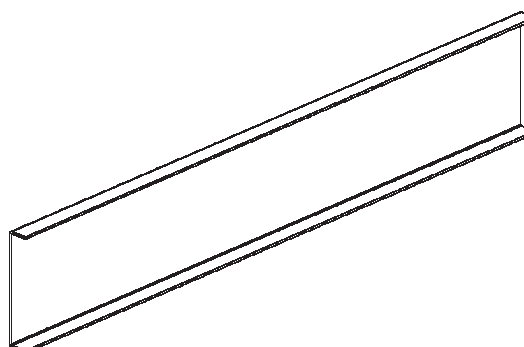
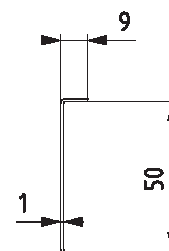

Slak-T SYSTEM

**APPLICAZIONI sistema telescopico - APLICACIÓN sistema telescópico
APPLICATIONS telescopic system - ANWENDUNGEN teleskopisches System**

B05E52

**Versione a parete/soffitto - 2 ante mobili - Versión de pared/techo. 2 puertas correderas
Wall/ceiling version. 2 moving glazings - Wand-,Deckevariante. 2 beweglichen Türflügel**

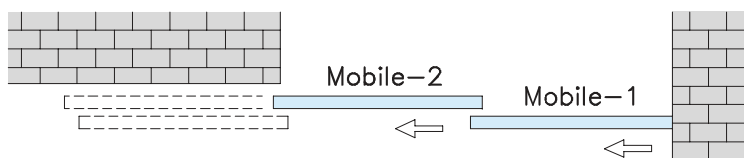

Parete - Pared - Wall - Wand

70kg	1300mm Max
------	---------------

Parete/soffitto - Pared/techo - Wall/ceiling - Wand-,Decke

90kg	1400mm Max
------	---------------

B05E54

**Versione a parete/soffitto - 4 ante mobili - Versión de pared/techo. 4 puertas correderas
Wall/ceiling version. 4 moving glazings - Wand-,Deckevariante. 4 beweglichen Türflügel**



Parete - Pared - Wall - Wand

70kg	1300mm Max
------	---------------

Parete/soffitto - Pared/techo - Wall/ceiling - Wand-,Decke

90kg	1400mm Max
------	---------------

B05E73

**Versione a soffitto. 3 ante : 2 mobili e 1 fissa - Versión de techo. 3 puertas: dos
correderas y una fija - Ceiling version. 3 glazings: 2 moving and 1 fixed -
Deckevariante. 3 Türflügel: 2 beweglich und 1 fest**

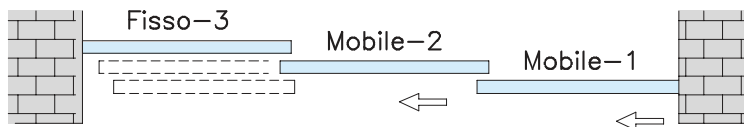

Soffitto - Techo - Ceiling - Decke

90kg	1400mm Max
------	---------------

B05E76

**Versione a soffitto. 6 ante : 4 mobili e 2 fisse - Versión de techo. Seis puertas: 4
correderas y dos fijas - Ceiling version. 6 glazings: 4 moving and 2 fixed -
Deckevariante. 6 Türflügel: 4 beweglich und 2 feste**

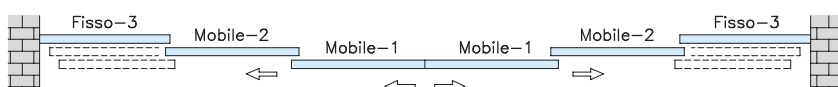

Soffitto - Techo - Ceiling - Decke

90kg	1400mm Max
------	---------------

B05E52 - B05E54
Parete/soffitto - Pared/techo Wall/ceiling - Wand-,Decke

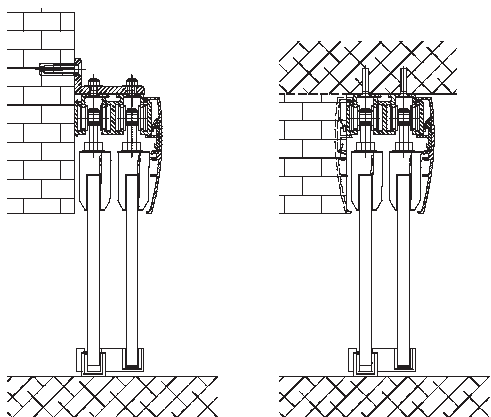

B05E73 - B05E76
Soffitto - Techo - Ceiling - Decke

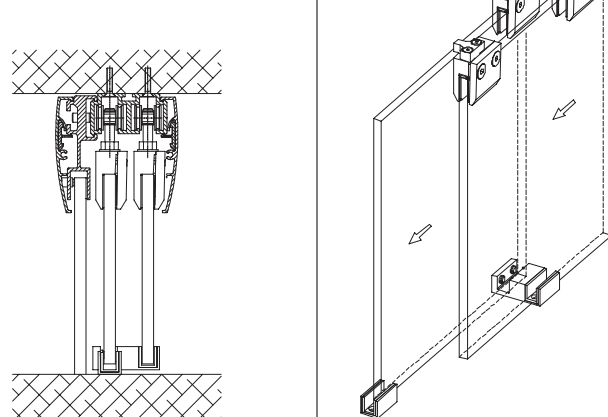

Sistema Slak-T - Sistema Slak-T - Slak-T system - Slak-T System

B05E52



- Set Slak-T scorrevole telescopico. Versione a soffitto/parete. 2 ante mobili.

- kit slak-t telescópico – corredero. Versión de techo/pared. Dos puertas correderas

- Slak-T set. Telescopic sliding. Ceiling/wall version. 2 moving glazings.

- Set Slak-T. Teleskopisches Schiebesystem. Decke-, Wandvariante. 2 beweglichen Türflügel.

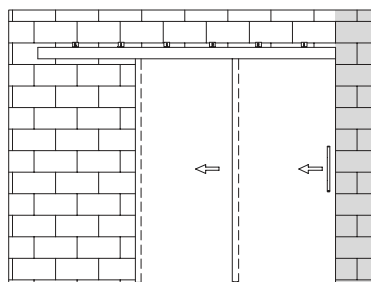

Compreso

1x B05EP11

2 x B905

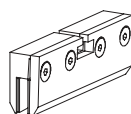

2 x BS10



2 x BS30



2 x B05EP14



1x B05EP12

2 x B905

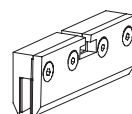

2 x BS10



2 x BS30



1 x B05EP13



1 x B05EP55



1 x BN50



Included

Non compreso

B05EP80

1 x 400mm.



B05EP40

B05EP40-3 (3mt.)

B05EP40-6 (6mt.)

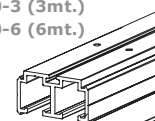

BS45

BS45-3 (3mt.)

BS45-6 (6mt.)



1 x B05EP60



5BN0



Not included

B05E54



- Set Slak-T scorrevole telescopico. Versione a soffitto/parete. 4 ante mobili.

- kit slak-t telescópico – corredero. Versión de techo/pared. Cuatro puertas correderas

- Slak-T set. Telescopic sliding. Ceiling/wall version. 4 moving glazings.

- Set Slak-T. Teleskopisches Schiebesystem. Decke-, Wandvariante. 4 beweglichen Türflügel.

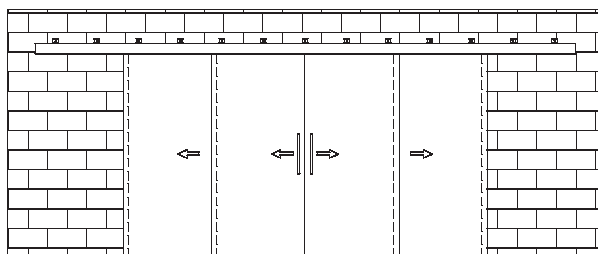

Compreso

2x B05EP11

2 x B905

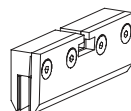

2 x BS10



2 x BS30



2 x B05EP14



2x B05EP12

2 x B905

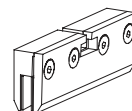

2 x BS10



2 x BS30



1 x B05EP13



1 x B05EP55



1 x BN50



Included

Non compreso

B05EP80

1 x 400mm.

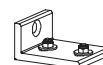

B05EP40

B05EP40-3 (3mt.)

B05EP40-6 (6mt.)

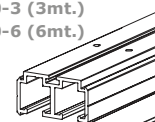

BS45

BS45-3 (3mt.)

BS45-6 (6mt.)



2 x B05EP60

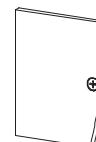

5BN0



Not included

B05E73



- Set Slak-T scorrevole telescopico. Versione a soffitto. 3 ante: 2 mobili e 1 fissa.
- kit slak-t telescópico – corredero. Versión de techo. Tres puertas: dos correderas y una fija
- Slak-T set. Telescopic sliding. Ceiling version. 3 glazings: 2 moving and 1 fixed.
- Set Slak-T. Teleskopisches Schiebesystem. Deckevariante. 3 Türflügel: 2 beweglich und 1 fest

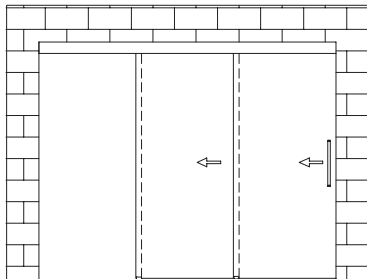

Compreso

1x B05EP11	1x B05EP12
2 x B905	2 x B905
2 x BS10	2 x BS10
2 x BS30	2 x BS30
2 x B05EP14	1 x B05EP13
	1 x B05EP55
	1 x BN50

Included

Non compreso

B05EP40
B05EP40-3 (3mt.)
B05EP40-6 (6mt.)

BS45
BS45-3 (3mt.)
BS45-6 (6mt.)

3 x BS70

5BN0

Not included

B05E76



- Set Slak-T scorrevole telescopico. Versione a soffitto. 6 ante: 4 mobili e 2 fisse.
- kit slak-t telescópico – corredero. Versión de techo. Seis puertas: cuatros correderas y dos fijas
- Slak-T set. Telescopic sliding. Ceiling version. 6 glazings: 4 moving and 2 fixed.
- Set Slak-T. Teleskopisches Schiebesystem. Deckevariante. 6 Türflügel: 4 beweglich und 2 feste.

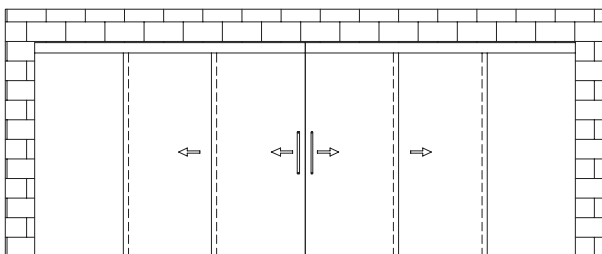

Compreso

2x B05EP11	2x B05EP12
2 x B905	2 x B905
2 x BS10	2 x BS10
2 x BS30	2 x BS30
2 x B05EP14	1 x B05EP13
	1 x B05EP55
	1 x BN50

Included

Non compreso

B05EP40
B05EP40-3 (3mt.)
B05EP40-6 (6mt.)

BS45
BS45-3 (3mt.)
BS45-6 (6mt.)

5 x BS70

5BN0

Not included

B05EP40

- Binario a 2 vie L = 3/6 mt.
- Binario de dos vias L = 3/6 mt.
- 2-ways rail L = 3/6 mt.
- 2-wege Schiene L = 3/6 mt.

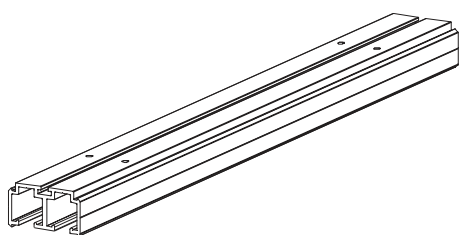
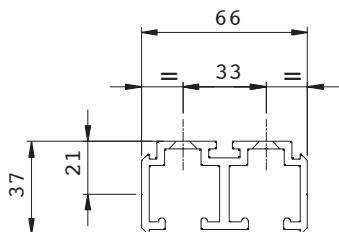

$$L \text{ barra} = L \text{ vano} + 100 + \left(\frac{L \text{ vano}}{n^{\circ} \text{ vetri}} \right)$$

$$L \text{ bar} = L \text{ space} + 100 + \left(\frac{L \text{ space}}{n^{\circ} \text{ glasses}} \right)$$

BS45

- Veletta Slak L = 3/6 mt.
- Cárter "Slak" L = 3/6 mt.
- Slak spandrel panel. L = 3/6 mt.
- Anlauf Slak. L = 3/6 mt.

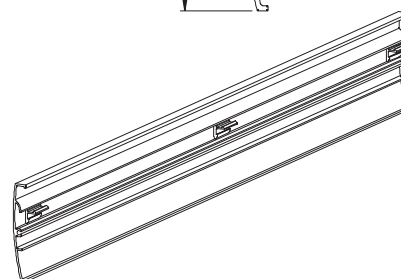
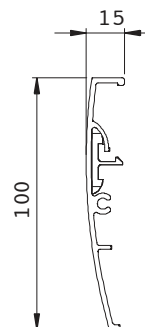

B05EP60

- Tappo binario a due vie.
- Tapa por carril de dos vias.
- Cap for 2-ways rail.
- Deckel für 2-wege Schiene.

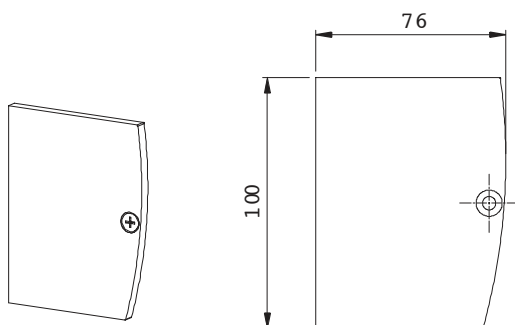

BS70

- Supporto fisso Slak L=300mm.
- Soporte Slak de fijo de L=300mm.
- Slak fixed support. L=300mm.
- Slak Schiene für feste Gehäuse L=300mm.

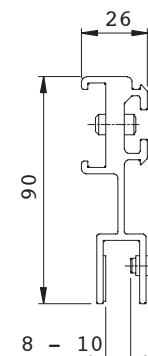
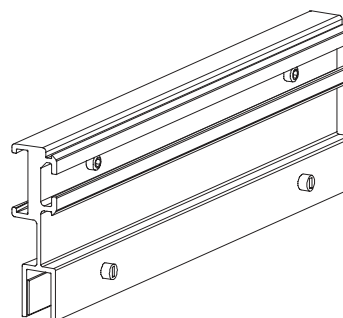

B05EP80

• Staffa di fissaggio a parete. Una ogni 400mm.

• Abrazadera de ajuste a pared. Una pieza, cada 400mm.

• Wall fixing plate. One each 400mm.

• Wandbefestigungsplatte. Eine jede 400mm.

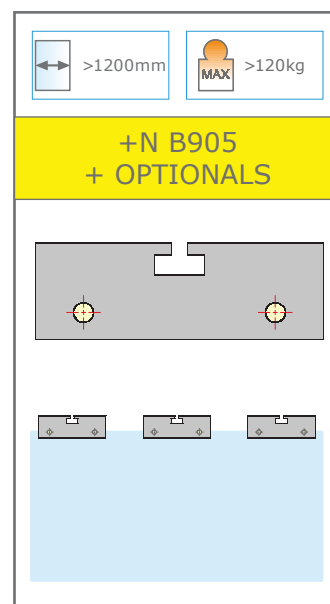
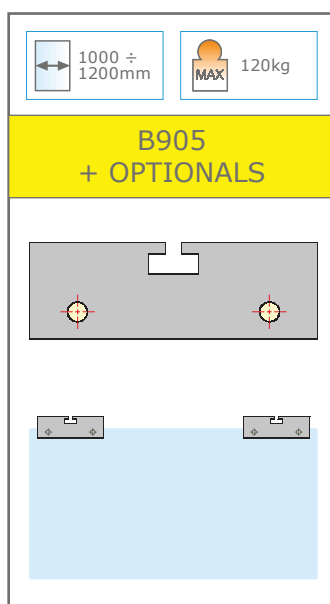
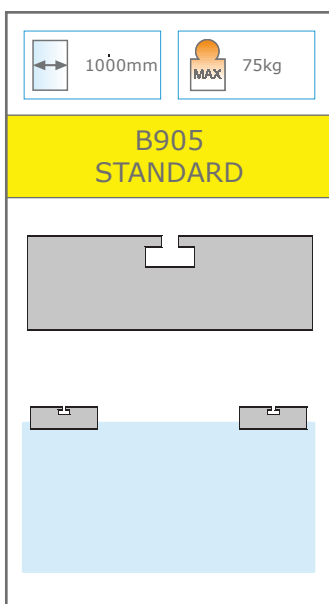
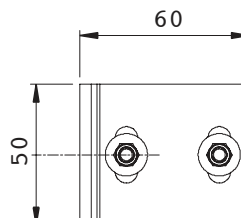
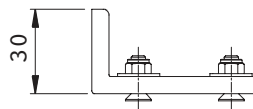
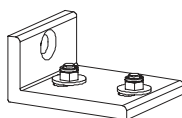

B05E52

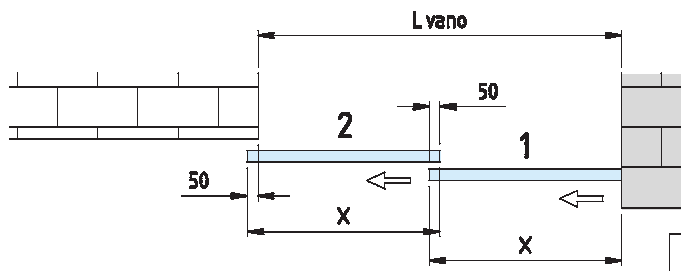
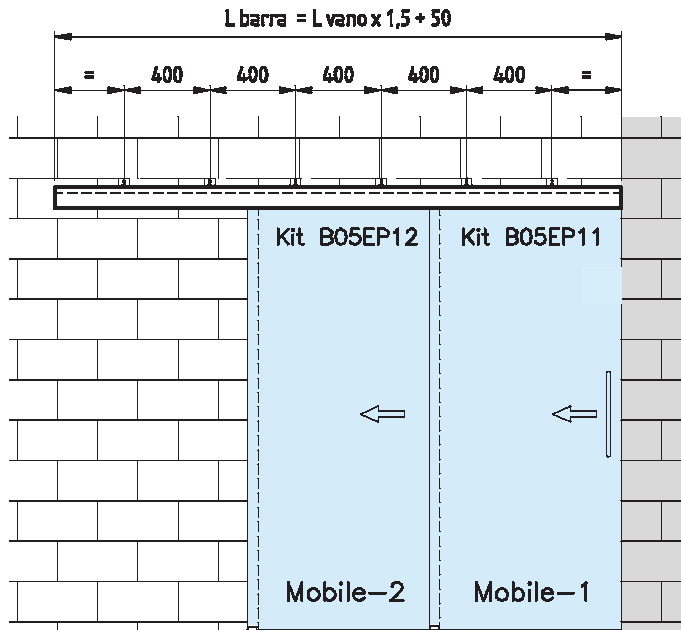

$X = (L \text{ vano} : 2) + 50$

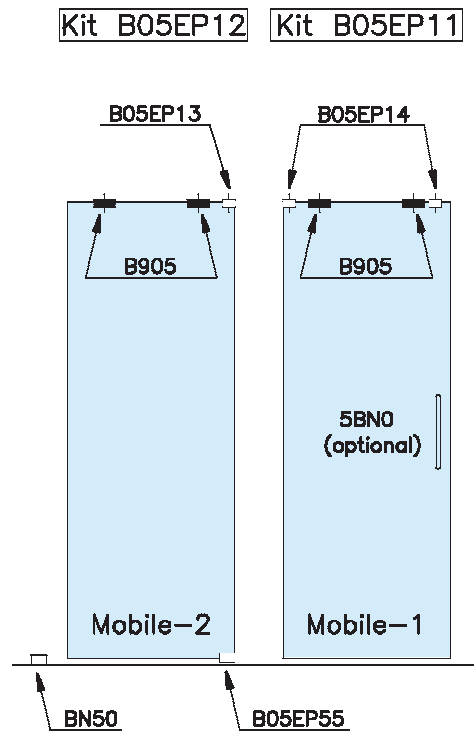
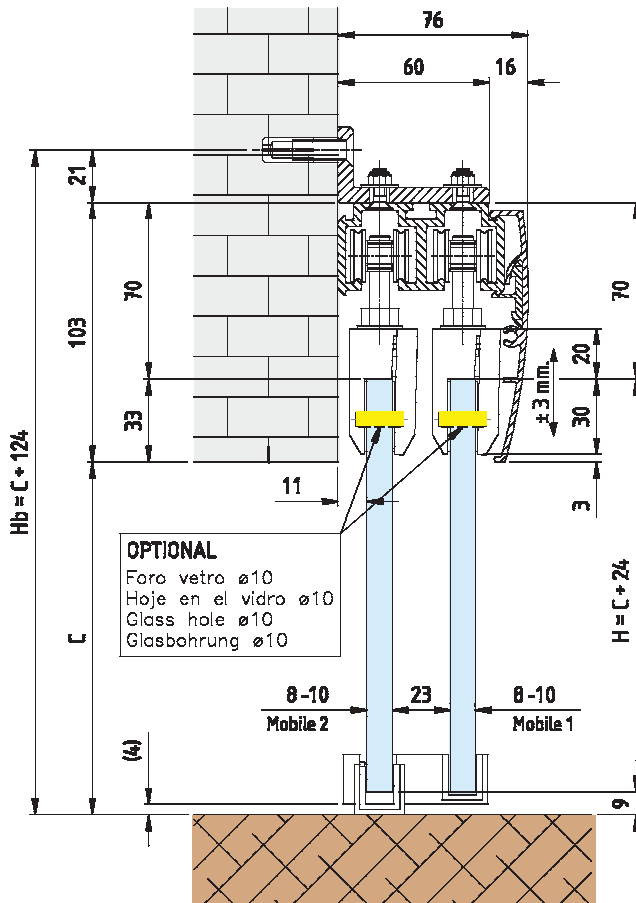

B05E54

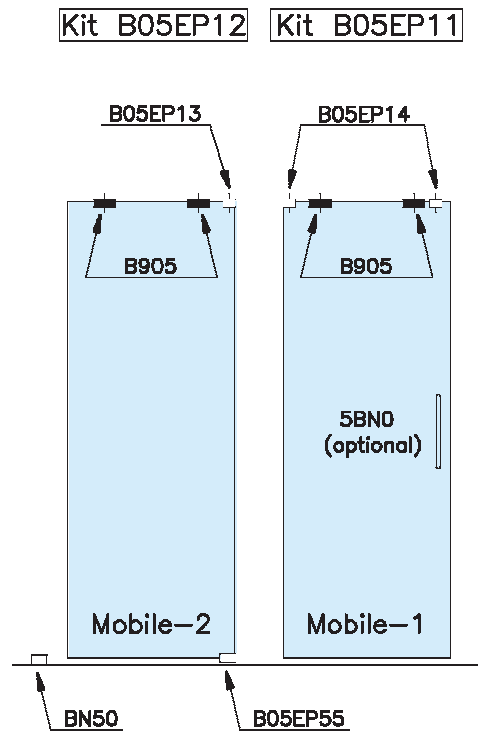
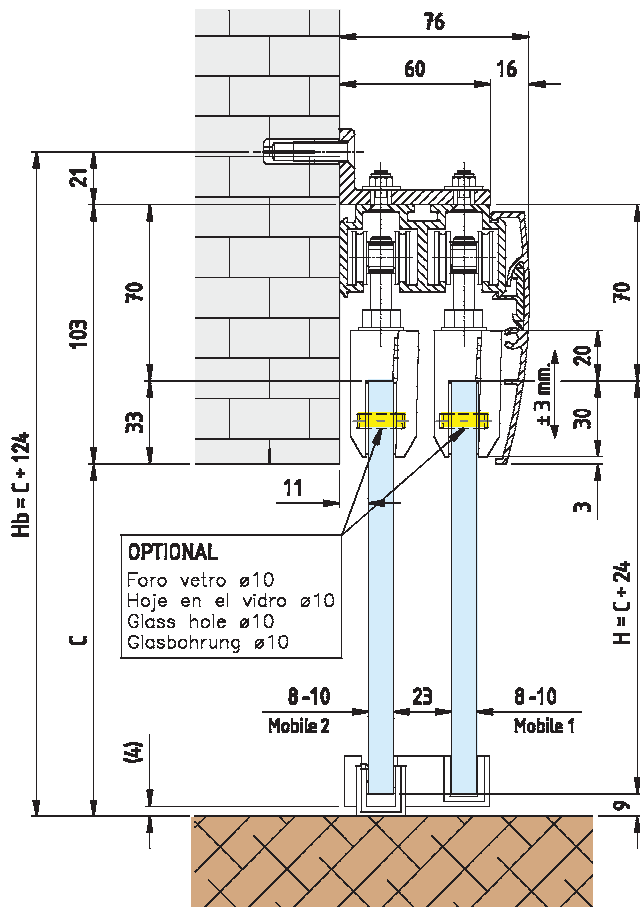
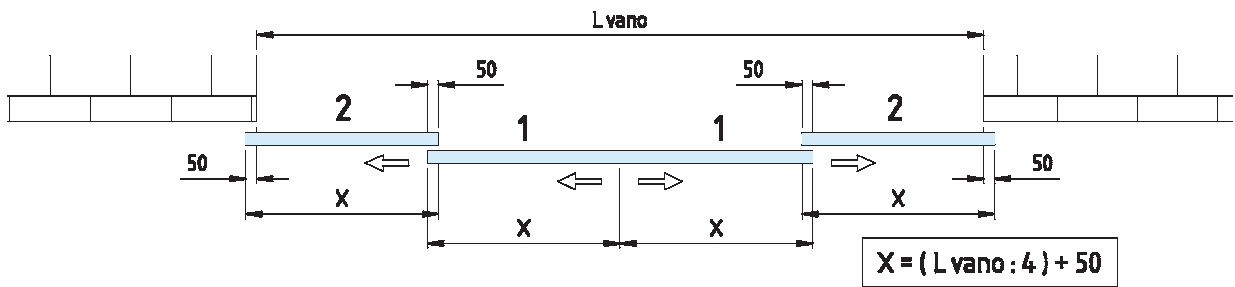
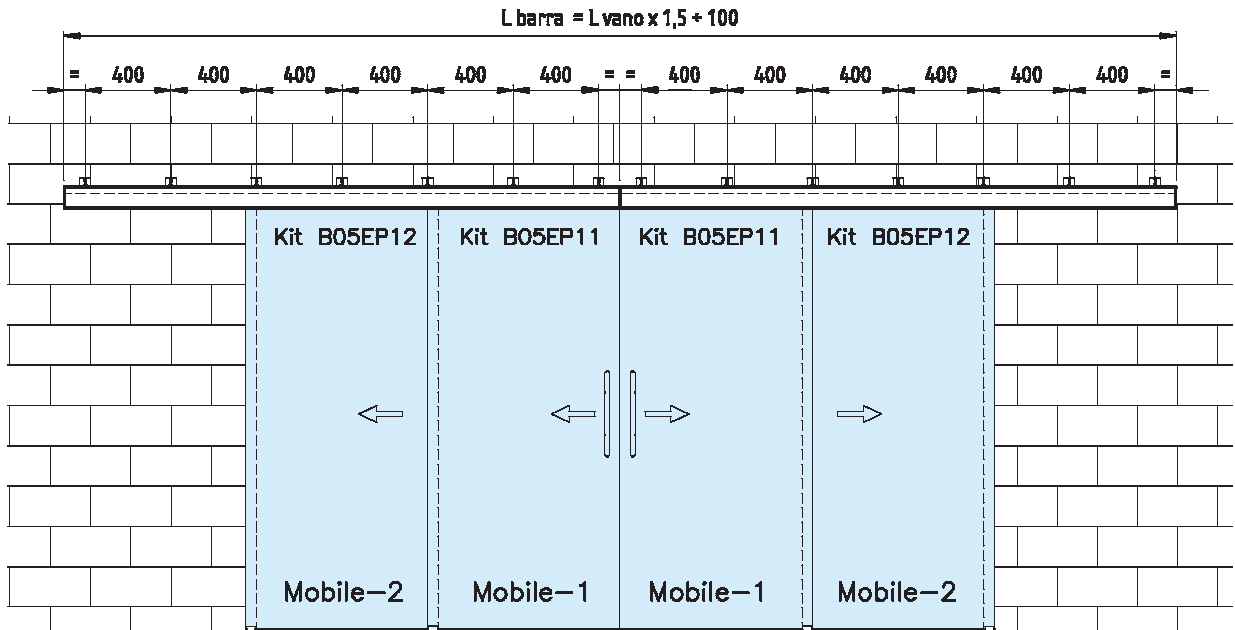

B05E73

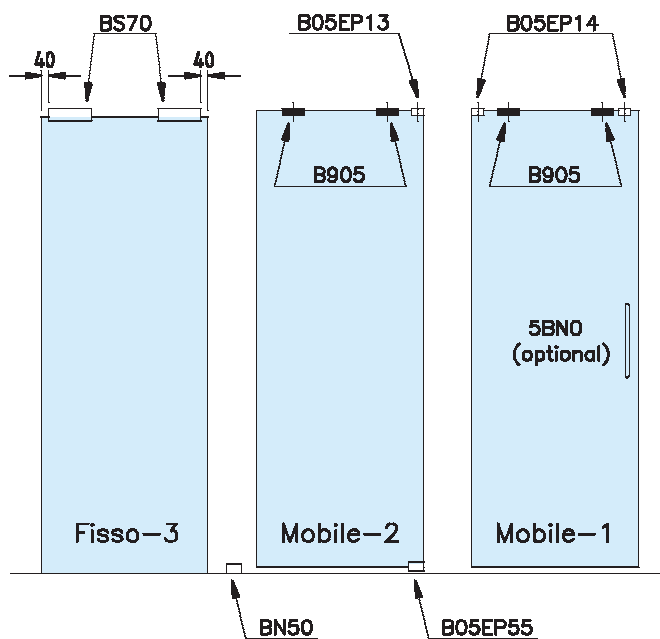
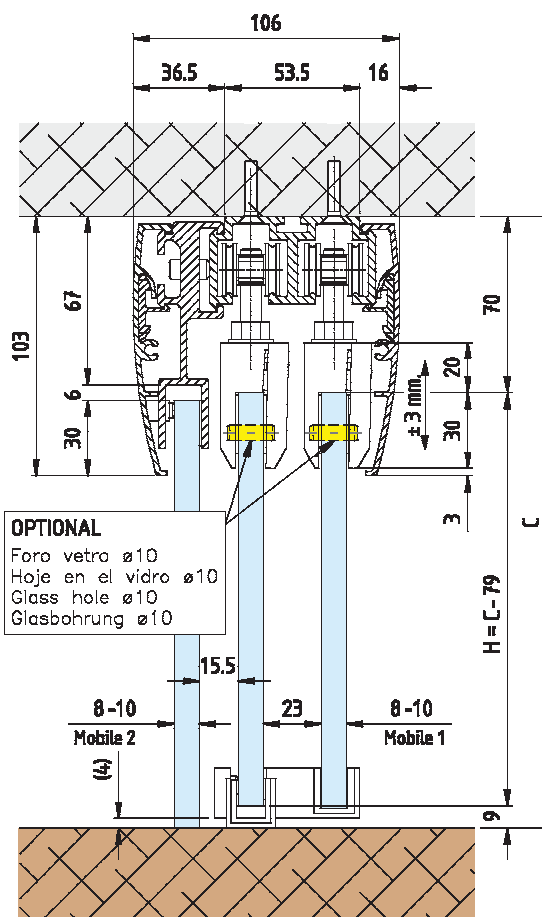
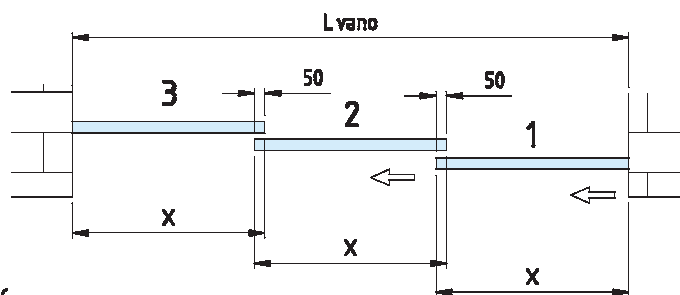
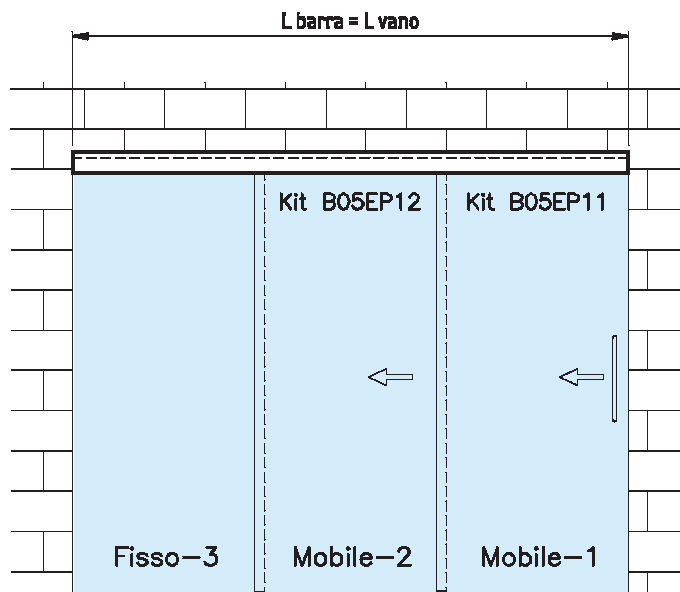

B05E76

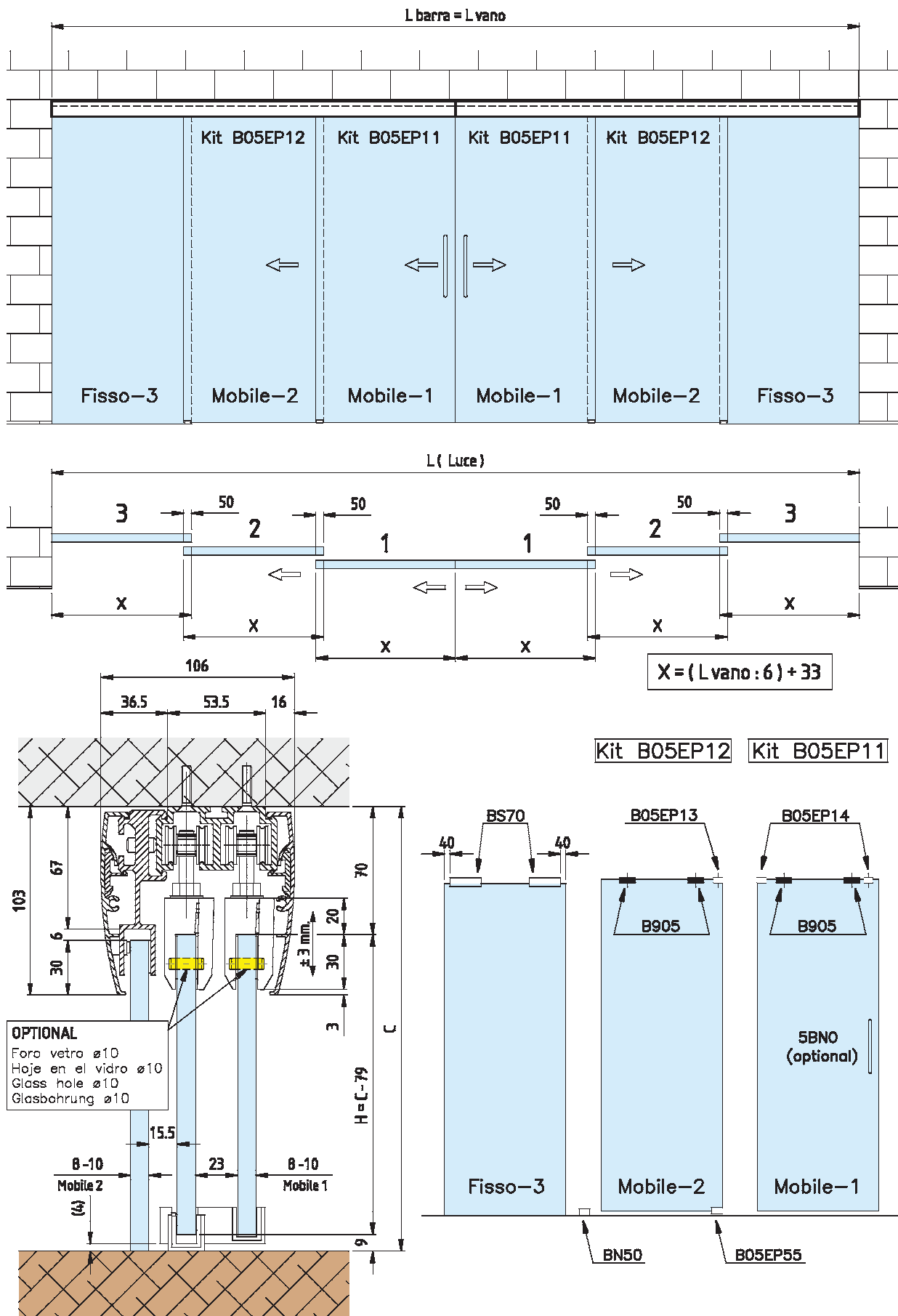

Slak-T B05E DETTAGLI DETALLES DETAILS DETAILLE

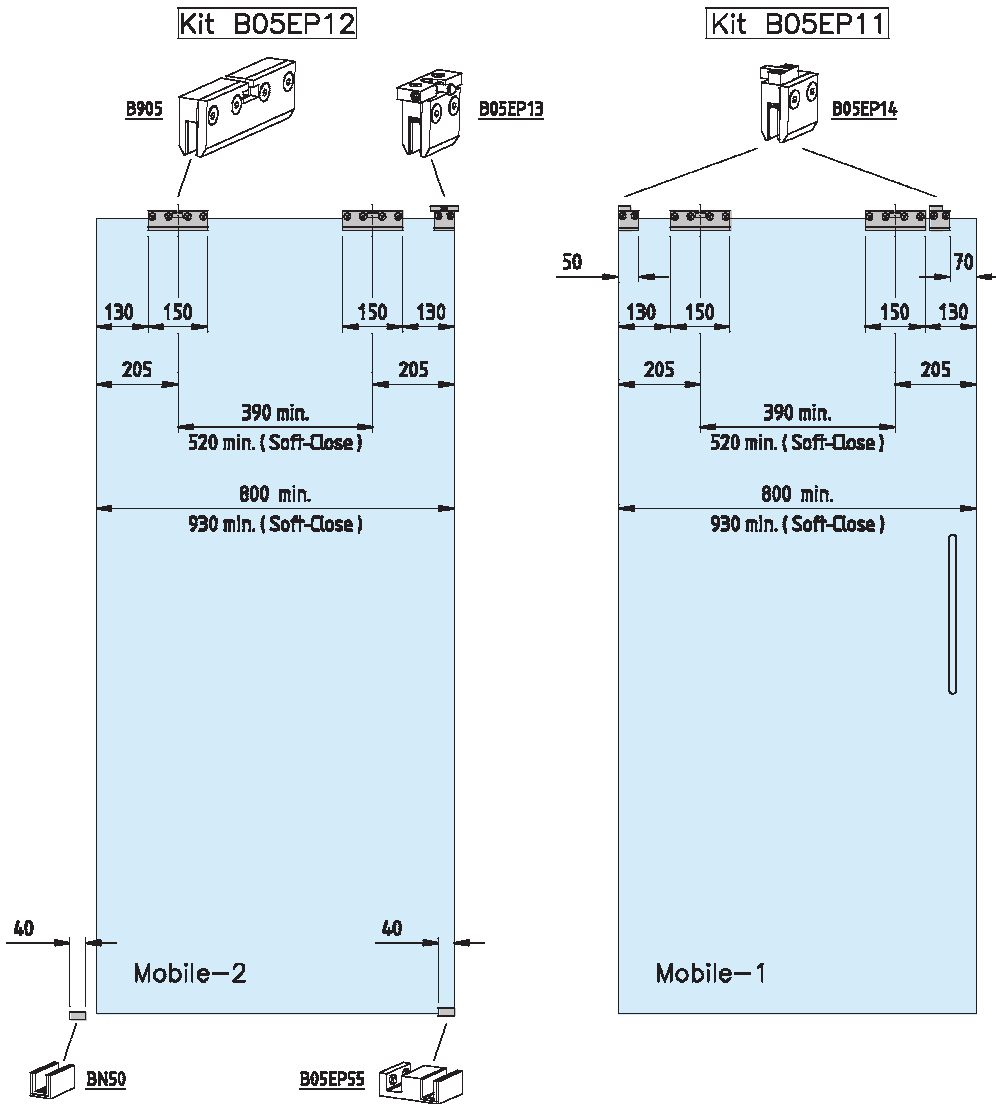

**ESEMPIO - EJEMPLO
EXAMPLE - BEISPIEL**

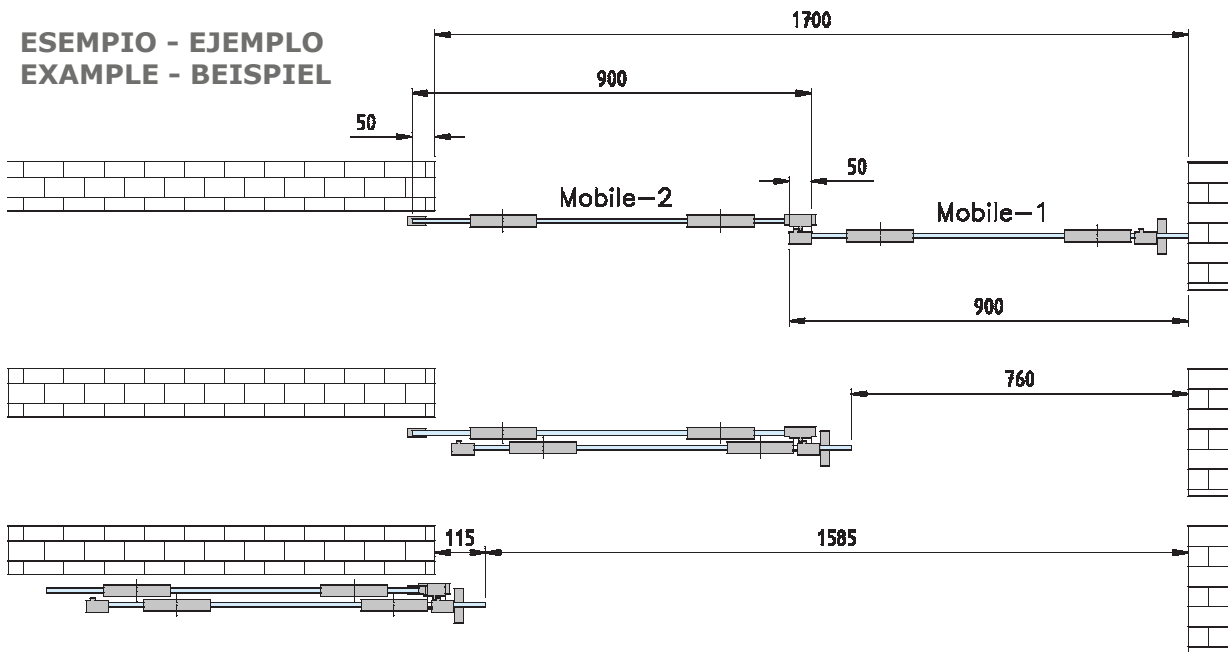

Sistema Slak-T - Sistema Slak-T - Slak-T system - Slak-T system - Slak-T System

B905

- Pinza per porta scorrevole.
- Pinza de sujeción para puerta corredera.
- Clamp for sliding door.
- Band für Schiebetür.

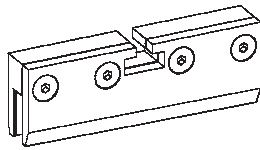
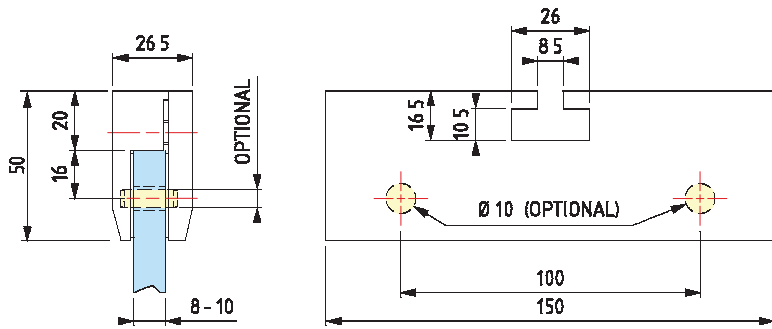

			STANDARD
			OPTIONAL
	>1200mm length icon"/>	>120kg MAX weight icon"/>	OPTIONAL +N B905

B925

--	--	--

- Pinza per porta scorrevole.
- Pinza de sujeción para puerta corredera.
- Clamp for sliding door.
- Band für Schiebetüre.

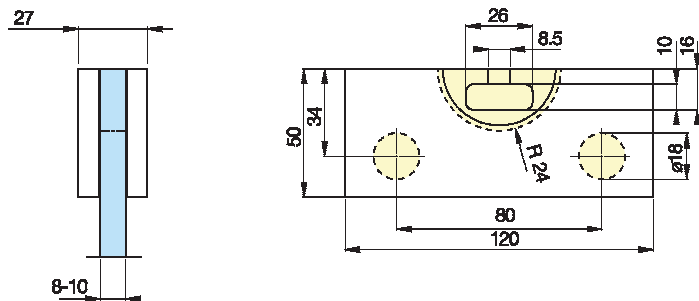
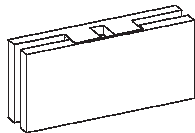

B92

--	--	--

- Pinza per porta scorrevole. Filetto 8mm (10mm a richiesta).
- Pinza de sujeción para puerta corredera. Rosca de 8 mm (10 mm a petición).
- Clamp for sliding door. 8mm thread (10mm on request).
- Band für Schiebetür. Gewinde 8mm (10mm auf Wunsch).

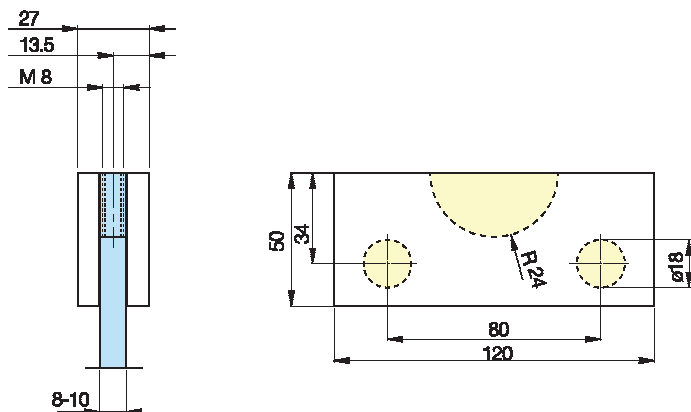
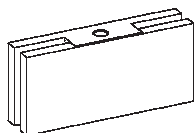

B94



- Serratura con gancio per porta scorrevole.
- Cerradura con gancho para puerta corredera.
- Lock with hook for sliding door.
- Schloss mit Haken für Schiebetür.

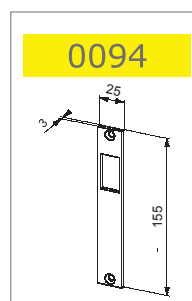
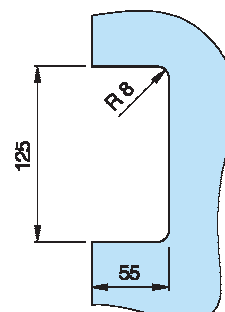
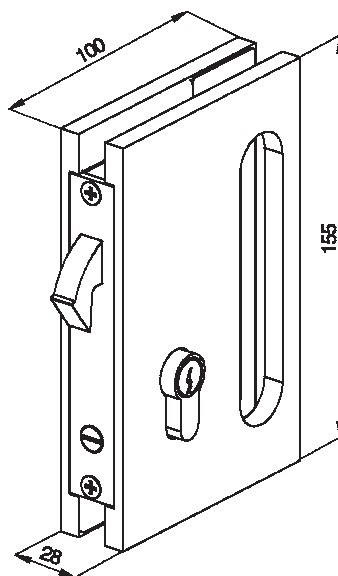
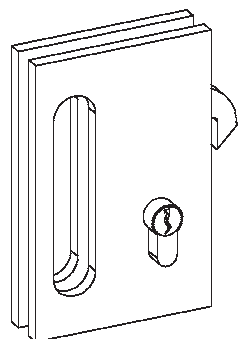

0094

B95



- Controserratura per porta scorrevole.
- Contra chapa para puerta corredera.
- Lock keeper for sliding door.
- Gegenschloss für Schiebetür.

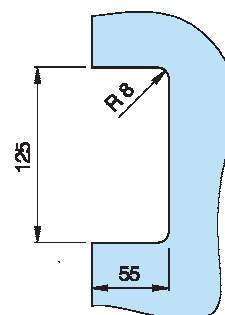
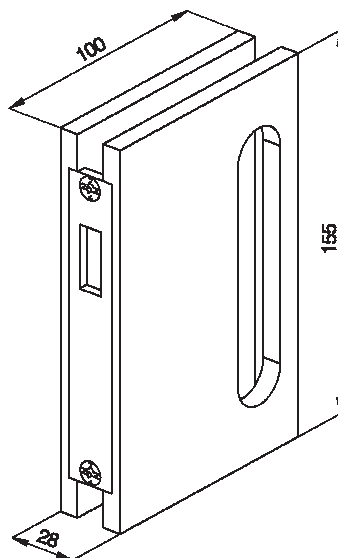
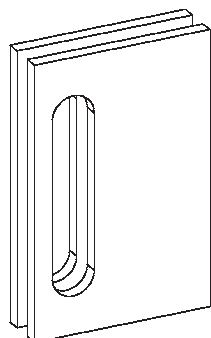

B96



- Serratura con gancio per porta scorrevole.
- Cerradura con gancho para puerta corredera.
- Lock with hook for sliding door.
- Schloss mit Haken für Schiebetür.

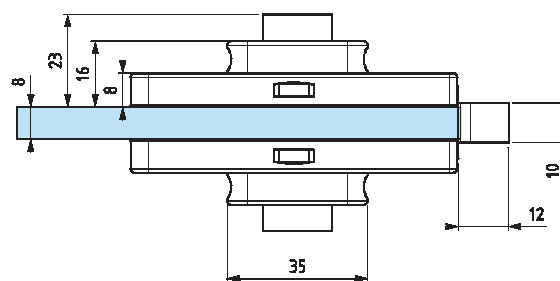
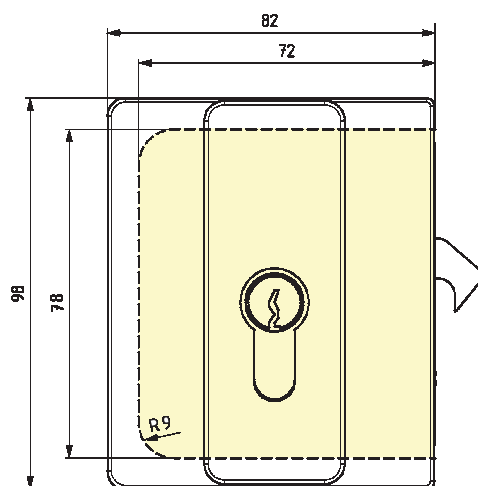
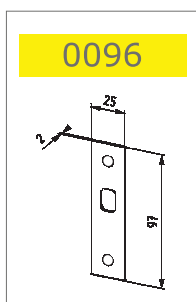
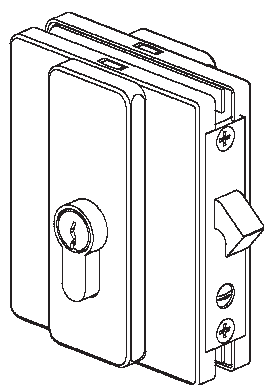

B97



- Controserratura per porta scorrevole.
- Contra chapa para puerta corredera.
- Lock keeper for sliding door.
- Gegenschloss für Schiebetür.

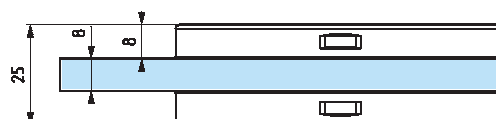
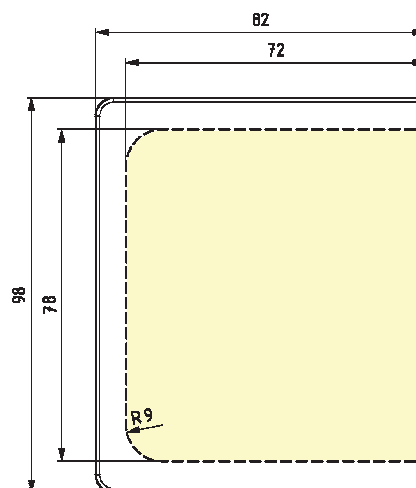
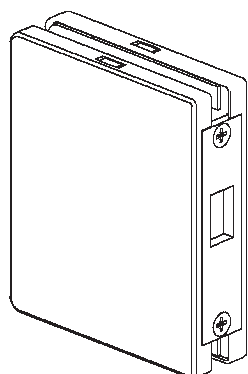

5B01



- Anello per porta scorrevole d. 40mm .
- Casquillo para puerta corredera d. 40mm .
- Sliding door ring diameter 40mm .
- Ring für Schiebetür. Durchmesser 40mm .

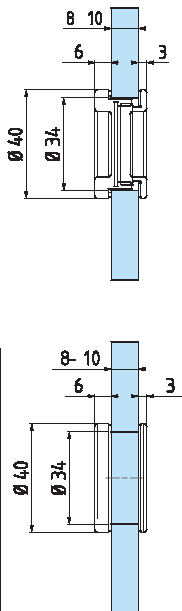
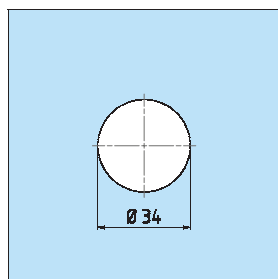

B93



- Maniglia per porta scorrevole.
- Tirador para puerta corredera.
- Small handle for sliding door.
- Kleine Handgriff für Schiebetür.

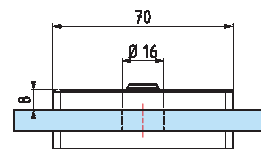
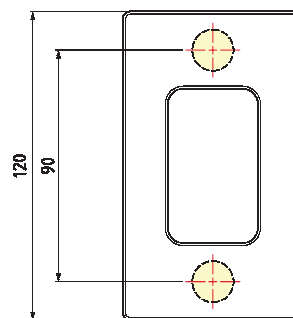
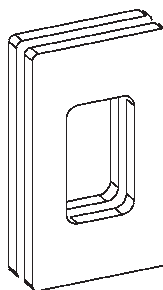

5B05



- Maniglia per porta scorrevole.
- Tirador para puerta corredera.
- Small handle for sliding door.
- Kleine Handgriff für Schiebetür.

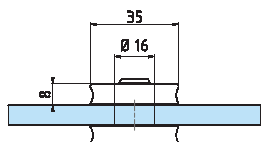
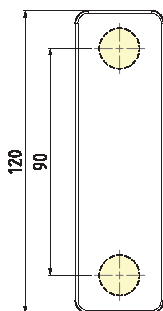

5BN0

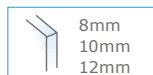

- Maniglia Neuscorre.
- Tirador "Neuscorre".
- Neuscorre handle.
- Neuscorre Türdrücker.

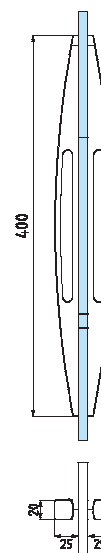
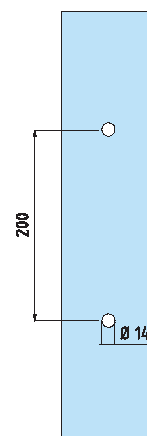

BS35

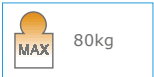

- SOFT-CLOSE meccanismo frenante per chiusure ammortizzate. Applicabile su richiesta ai sistemi serie Slak.
- SOFT-CLOSE mecanismo de freno para el bloqueo de amortización aplicable contra demanda a el sistema series Slak.
- SOFT-CLOSE breaking mechanism for amortized locking, applicable on demand to Slak system series.
- SOFT-CLOSE Bremsmechanismus für gedämpfte Schließung und ist bei Bedarf an Slak systems.

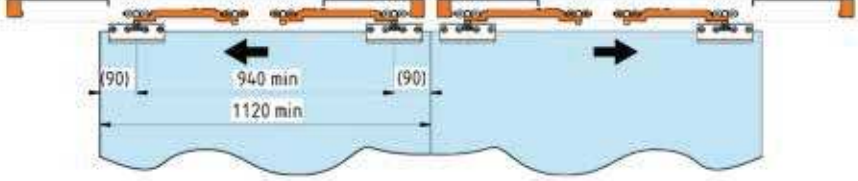
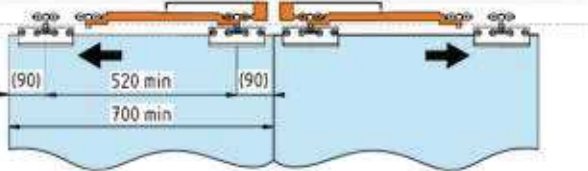
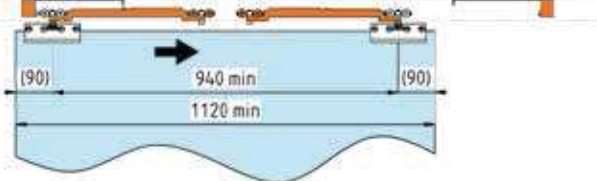
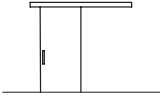
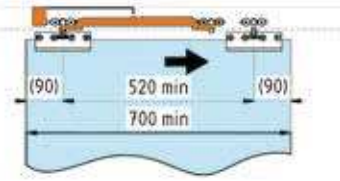
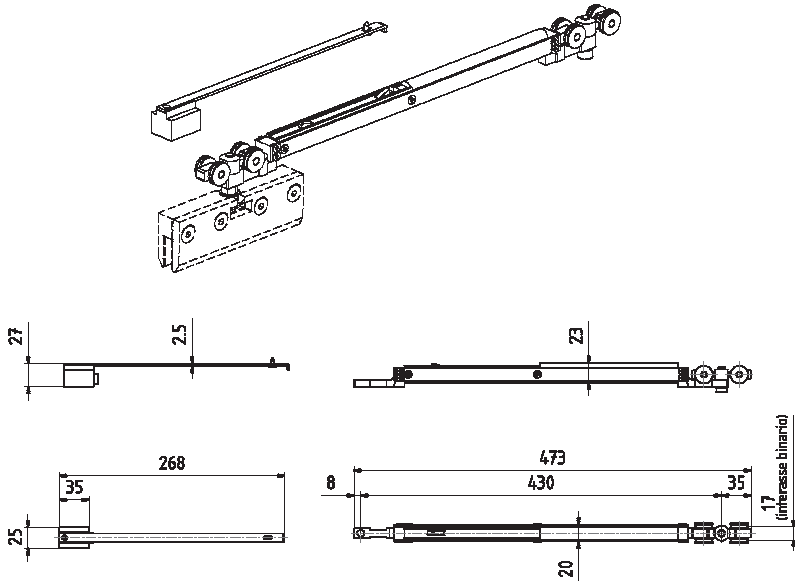

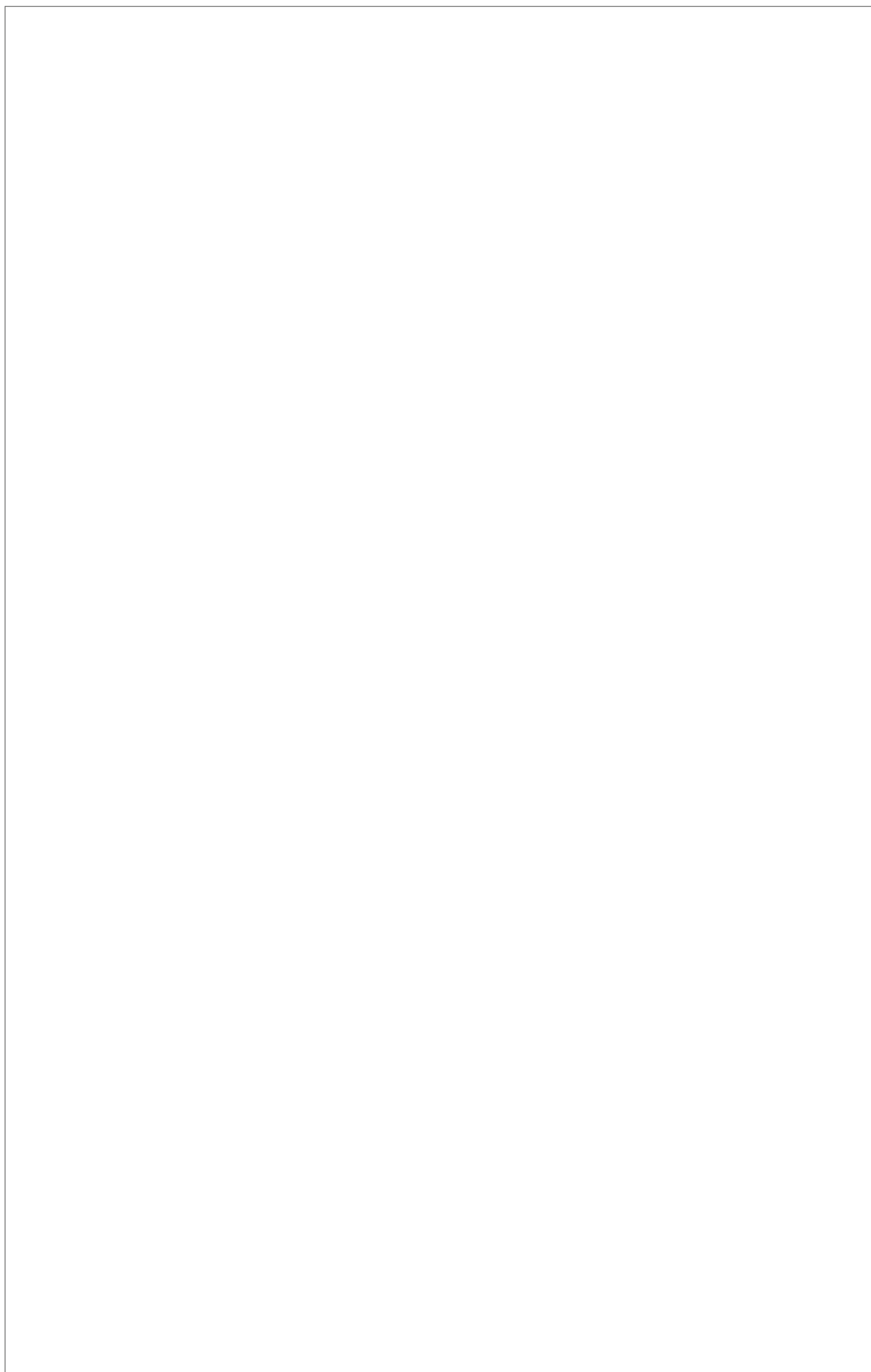

BF00

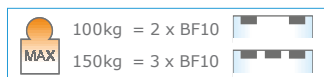

- Kit scorrevole Flo ad un anta - fissaggio su vetro.
- kit Flo para una puerta corredera y fijación en el vidrio.
- Sliding set Flo – one glazing fixing on glass.
- Set Schiebeseystem Flo mit einem Flügel – Befestigung am Glas.

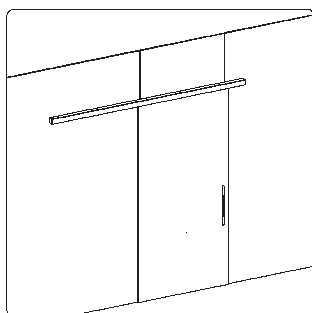

Compreso

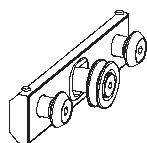

2X
BF10

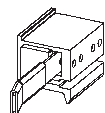

2X
BF30

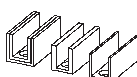

1X
BN50



2X
BF60



6X
BF70

Included

Non compreso



BF40
BF40-2 (2,5m)
BF40-5 (5m)



BF45
BF45-2 (2,5m)
BF45-5 (5m)



5BN0

Not included

BF01

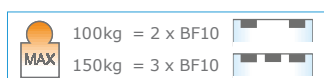

- Kit scorrevole Flo a due ante - fissaggio su vetro.
- Kit Flo para dos puertas correderas y fijación en el vidrio.
- Sliding set Flo – on two glazing fixing on glass.
- Set Schiebeseystem Flo mit zwei Flügeln – Befestigung am Glas.

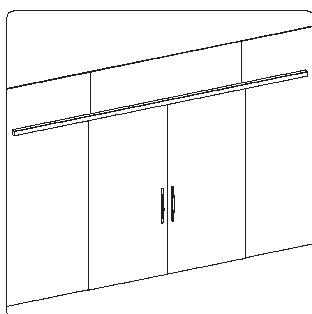

Compreso

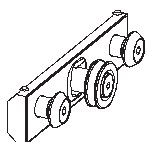

4X
BF10

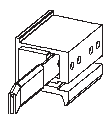

4X
BF30

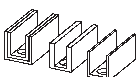

2X
BN50

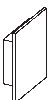

2X
BF60



9X
BF70

Included

Non compreso



BF40
BF40-2 (2,5m)
BF40-5 (5m)



BF45
BF45-2 (2,5m)
BF45-5 (5m)

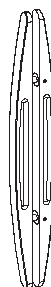

5BN0

Not included

BF03

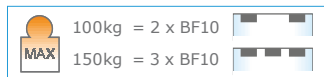

- Kit scorrevole Flo ad un anta - fissaggio a vetro con muro laterale.
- Kit para puerta corredera Flo una puerta- fijación vidrio a pared lateral.
- Sliding set Flo – one glazing fixing on glass with sideway wall.
- Set Schiebeseystem FLO mit einem Flügel - Befestigung am Glas und seitliche Wand.

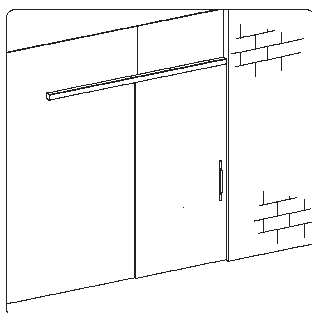

Compreso

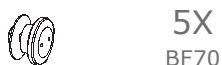
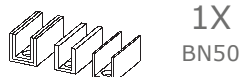
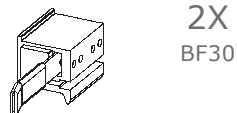
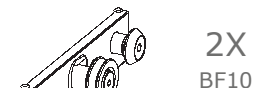

Included

Non compreso

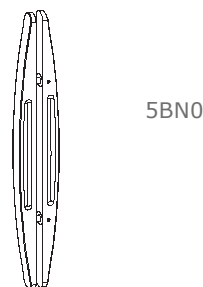
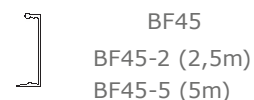
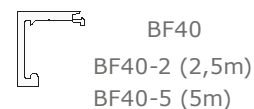

Not included

BF05

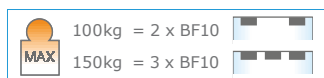

- Kit scorrevole Flo ad un anta - fissaggio su muro.
- Kit Flo para una puerta corredera y fijación en la pared.
- Sliding set Flo – one glazing fixing on wall.
- Set Schiebeseystem Flo mit einem Flügel - Befestigung an der Wand.

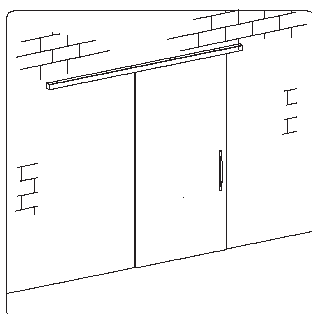

Compreso

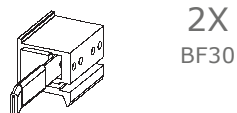
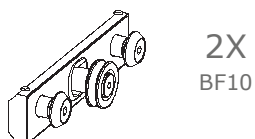

Included

Non compreso

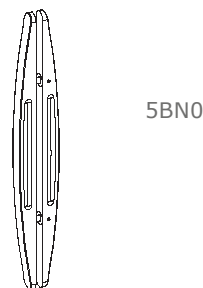
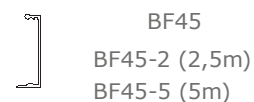
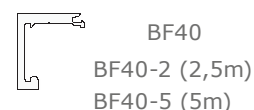

Not included

BF06

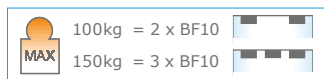

- Kit scorrevole Flo a due ante - fissaggio su muro o a soffitto.
- Kit Flo para dos puertas correderas y fijación en la pared o a techo.
- Sliding set Flo – two glazings fixing on wall or ceiling.
- Beschlagset Zweiflügelige Schiebetür Flo mit Befestigung an Wand oder Decke.

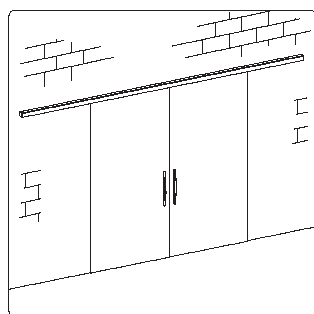

Compreso

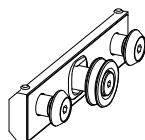

4X
BF10

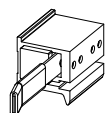

4X
BF30

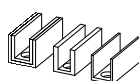

2X
BN50

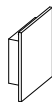

2X
BF60

Included

Non compreso



BF40
BF40-2 (2,5m)
BF40-5 (5m)



BF45
BF45-2 (2,5m)
BF45-5 (5m)



5BN0

Not included

BF07

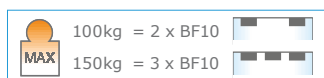

- Kit scorrevole Flo ad un ante - fissaggio a soffitto.
- Kit para puerta corredera Flo una puerta- fijación a techo.
- Sliding set Flo – one glazing fixing on ceiling.
- Set Schiebesystem Flo mit einem Flügel - Deckebefestigung.

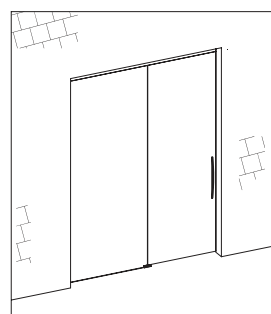

Compreso

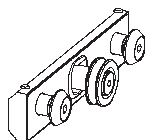

2X
BF10

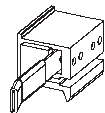

2X
BF30

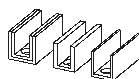

1X
BN50

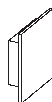

2X
BF60

Included

Non compreso

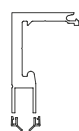

BF75
BF75-2 (2,5m)
BF75-5 (5m)
+ PCC016



BF45
BF45-2 (2,5m)
BF45-5 (5m)



5BN0

Not included

BF08

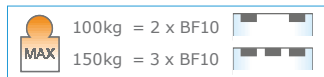

- Kit scorrevole Flo a due ante - fissaggio a soffitto.
- Kit Flo para dos puertas correderas y fijación a techo.
- Sliding set Flo – on two glazing fixing on ceiling.
- Set Schiebesystem Flo mit zwei Flügeln –Deckebefestigung.

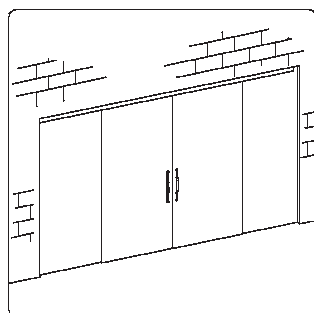

Compreso

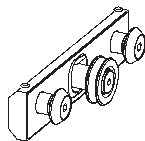

4X
BF10

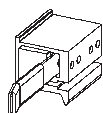

4X
BF30

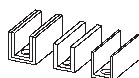

2X
BN50

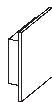

2X
BF60

Included

Non compreso

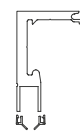

BF75
BF75-2 (2,5m)
BF75-5 (5m)
+ PCC016



BF45
BF45-2 (2,5m)
BF45-5 (5m)



5BN0

Not included

BF40

- Barra per sistema scorrevole Flo. Disponibile nelle lunghezze: 2,5m (BF40-2) e 5m (BF40-5).
- Barra para puerta corredera Flo. Disponible en 2.5 metros (BF40-2) y 5 metros (BF40-5).
- Bar for sliding system Flo - Available in following lengths : 2,5 mt (BF40-2) and 5 mt (BF40-5)
- Stange für Schiebeyesystem Flo. In den Längen: 2,5m (BF40-2) und 5m (BF40-5) verfügbar.

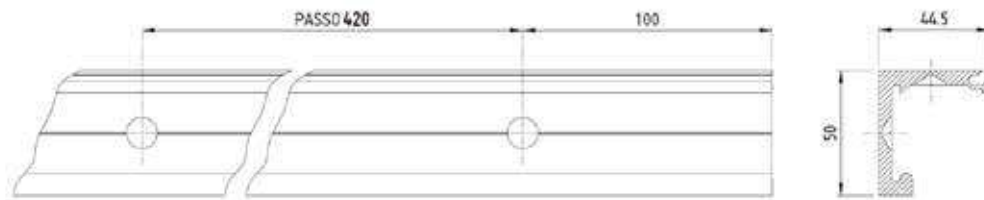

LE BARRE VENGONO FORNITE CON PREFORATURE CIECHE A PASSO 400 PER IL FISSAGGIO A MURO (PARETE O SOFFITTO) - LA BARRA VIENE MANUFACTURADA CON AGUJEROS CIEGOS DE PASO 400 PARA LA FIJACIÓN (PARED O TECHO) - THE BARS ARE SUPPLIED WITH BLIND DRILLING BY SPACING 400 FOR FIXING WALL (WALL OR CEILING) - DIE STANGEN SIND MIT SACKLÖCHER MIT ABSTAND 400 FÜR DIE WANDFIXIERUNG (WAND ODER DECKE) GELIEFERT.

- STANGENBEFESTIGUNGSSCHEMA BF40

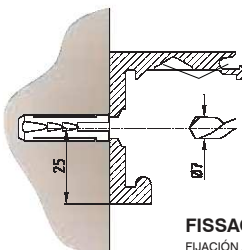
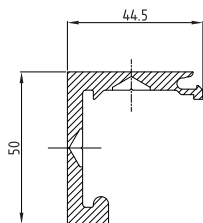
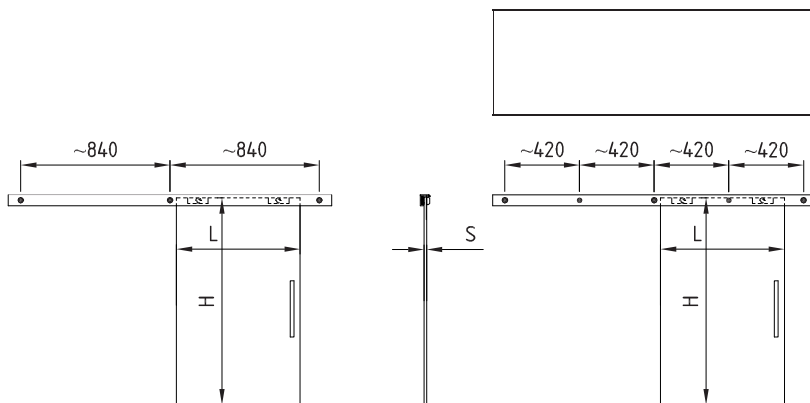

FISSAGGIO A PARETE
FIJACIÓN A PARED

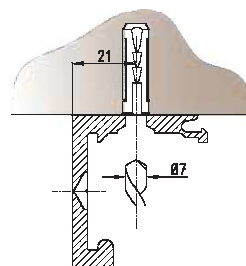

FISSAGGIO A TECHO
FIJACIÓN A TECHO

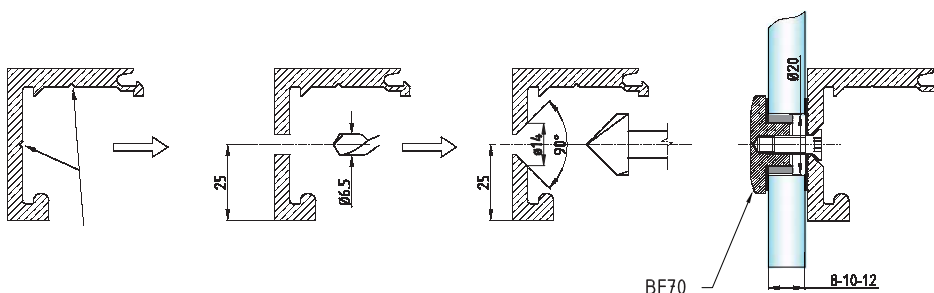

BF00

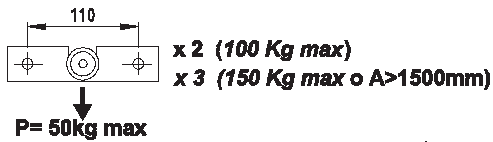
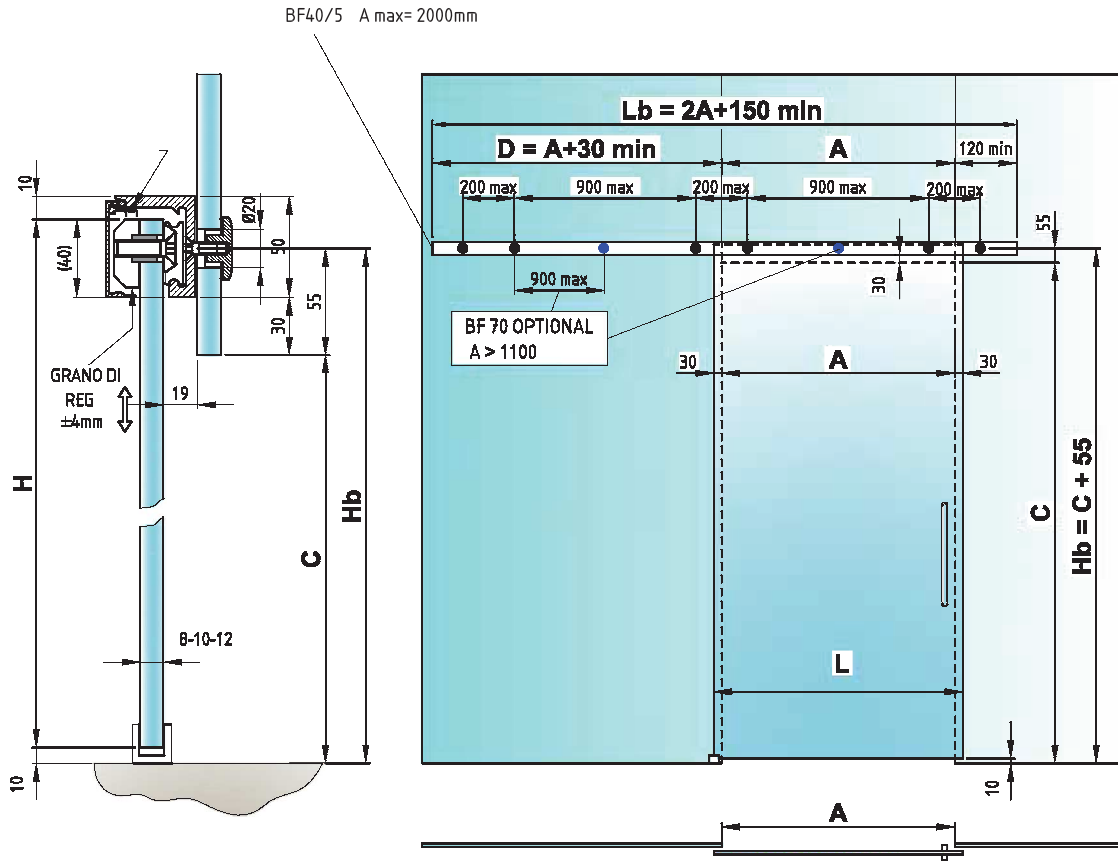

Applicazioni fuori standard su richiesta
Not standard application upon request

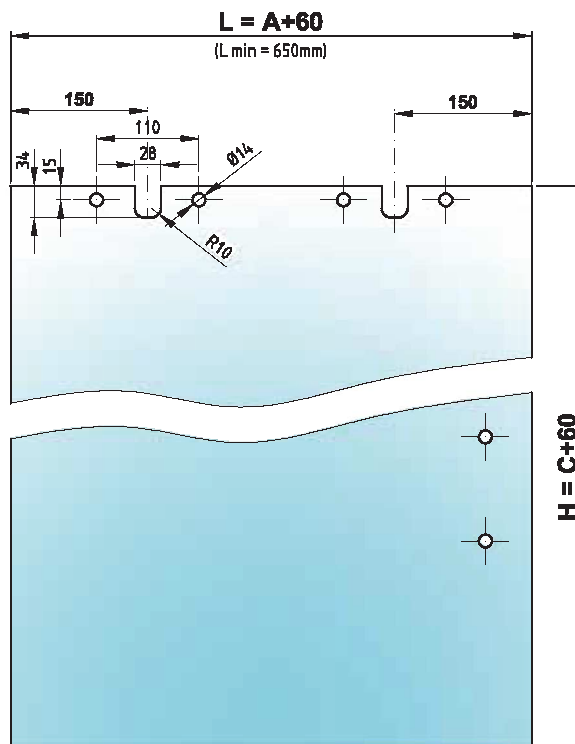

BF01

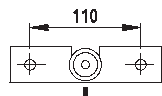
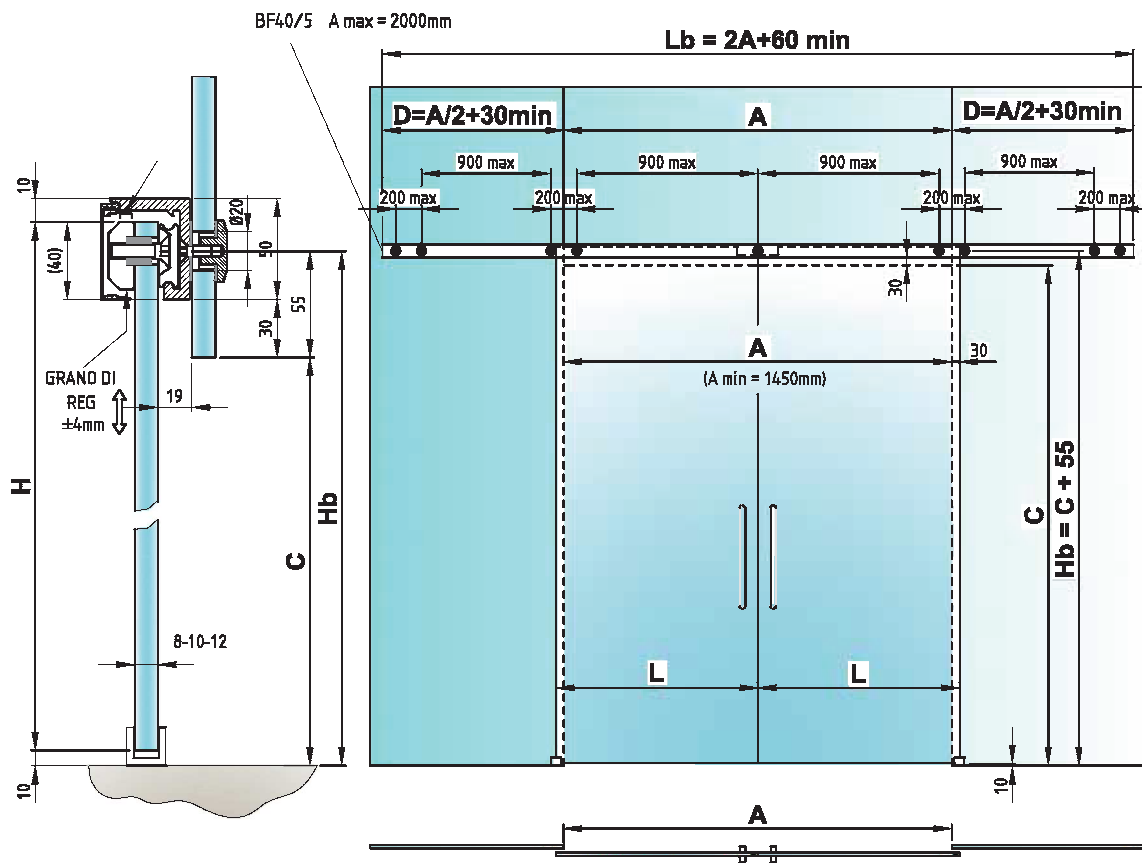

x 2 (100 Kg max)
Applicazioni P > 100 Kg e A > 2000 su richiesta
Application P > 100 Kg or A > 2000mm upon request

P = 50kg max

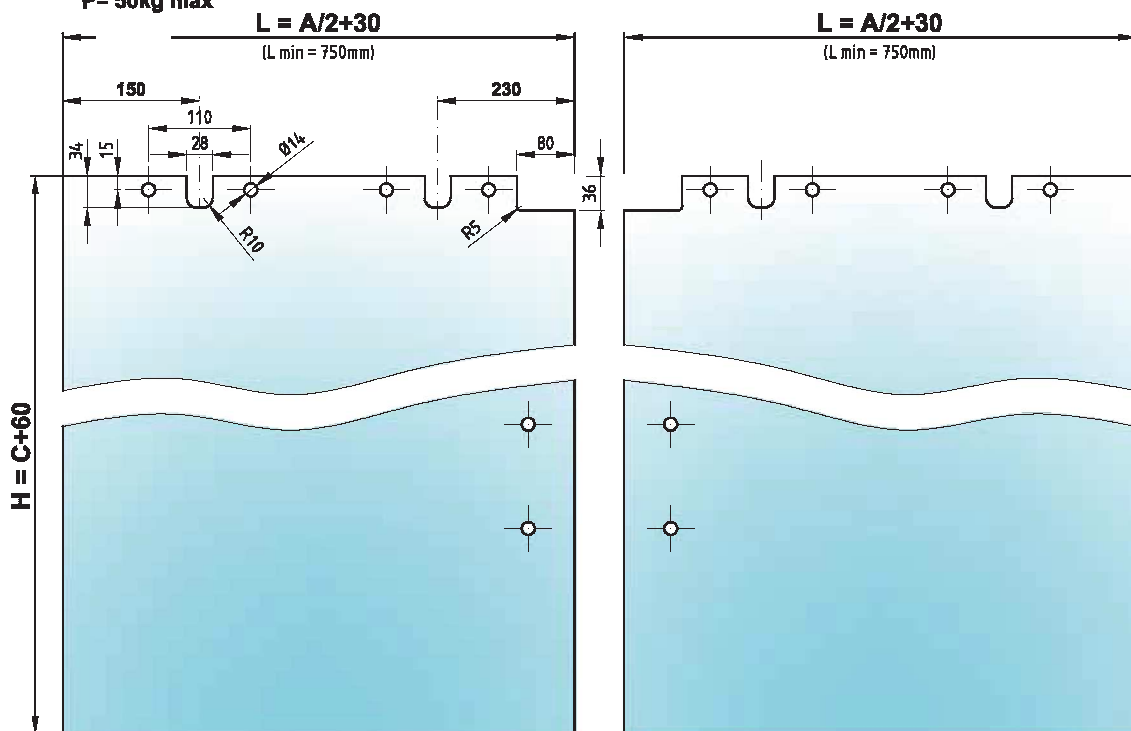

BF03

BF40/2 A max = 1100mm
BF40/5 A max = 2000mm

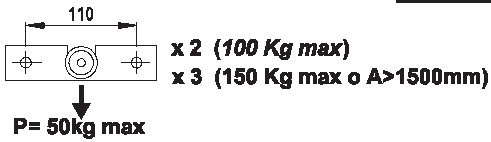
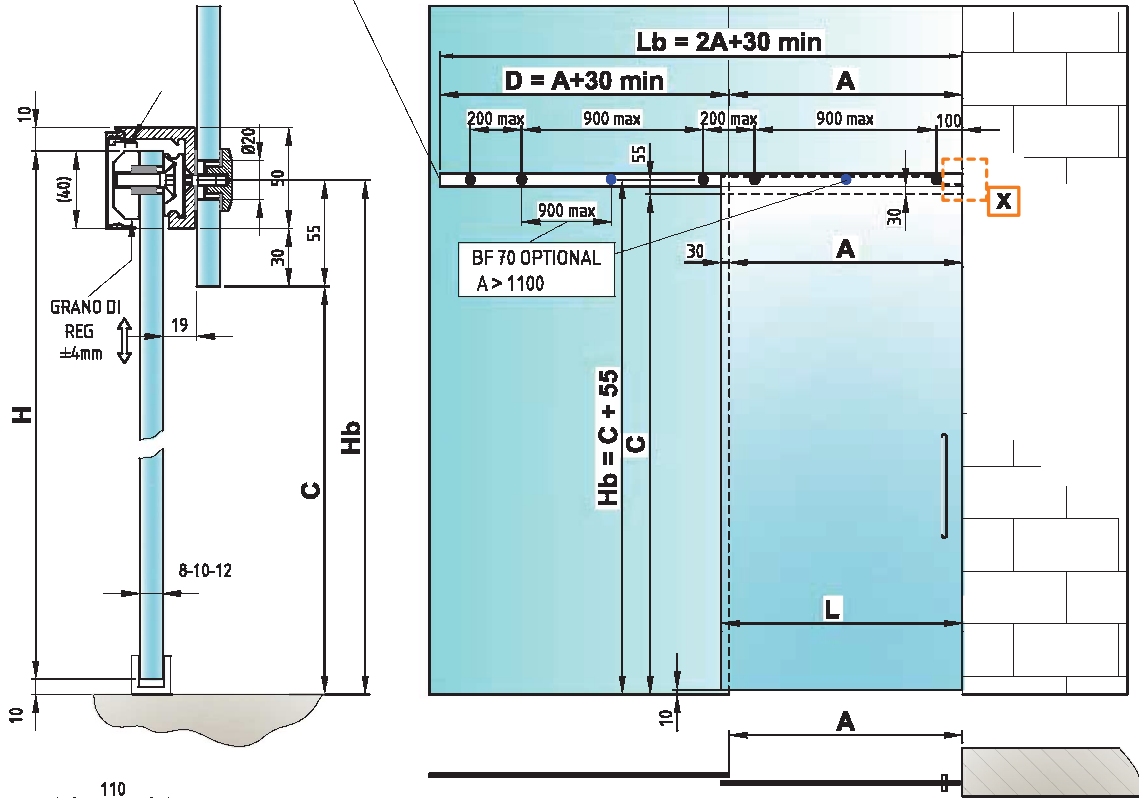

Applicazioni fuori standard su richiesta
Not standard application upon request

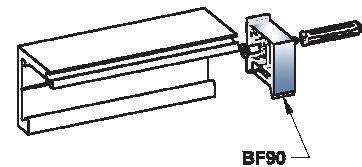
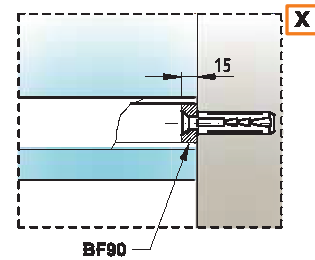
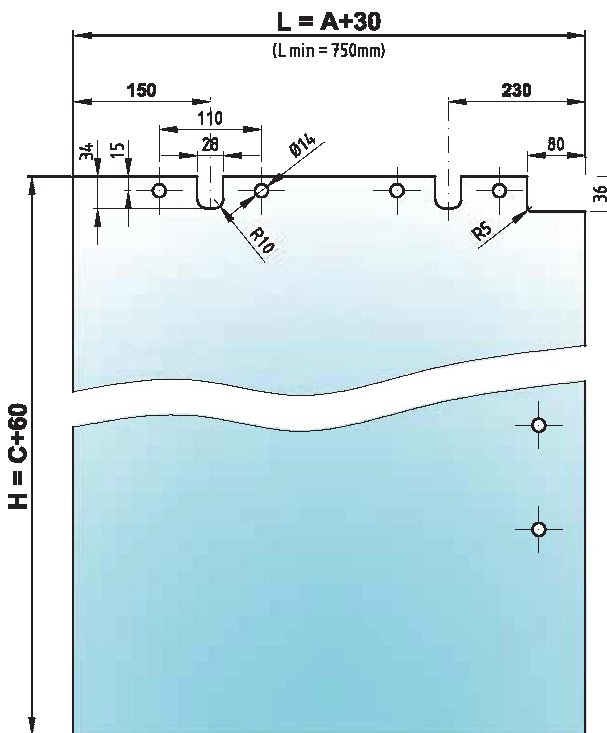

TASSELLO FISSAGGIO
BARRA A MURO

BF05

BF40/5 A max= 2300mm

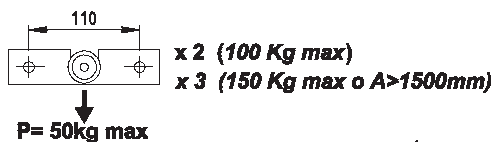
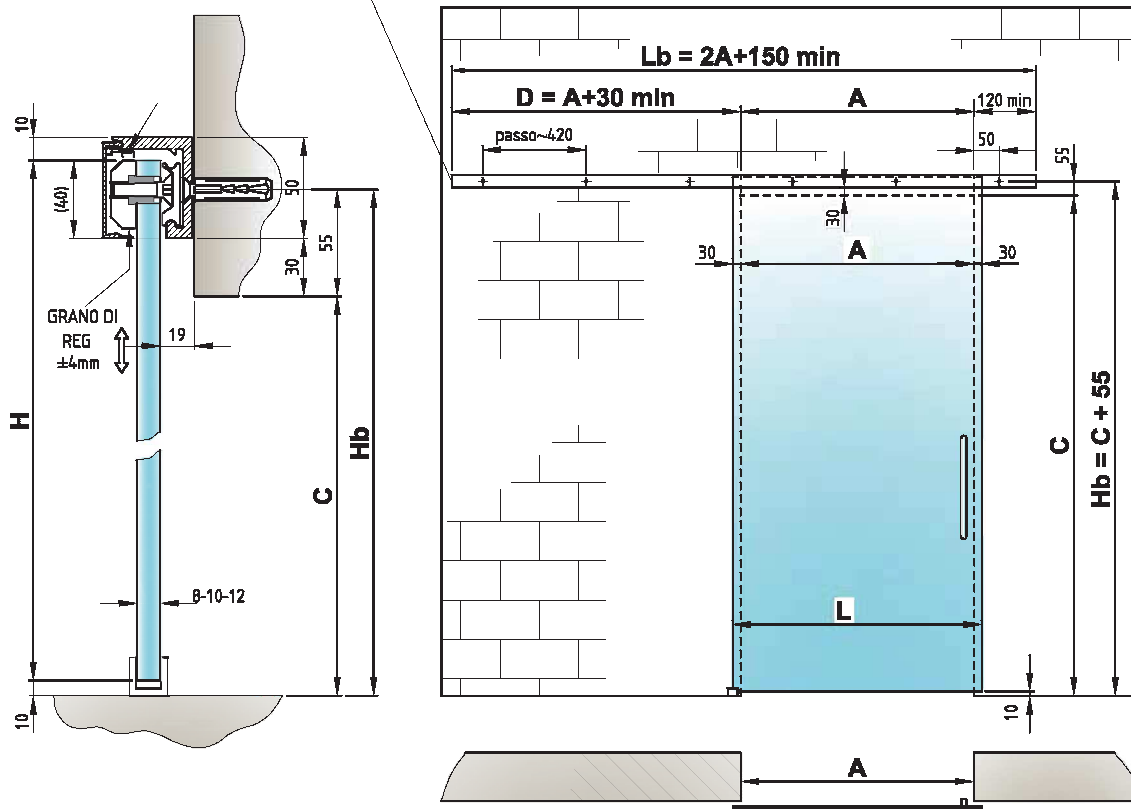

Applicazioni fuori standard su richiesta
Not standard application upon request

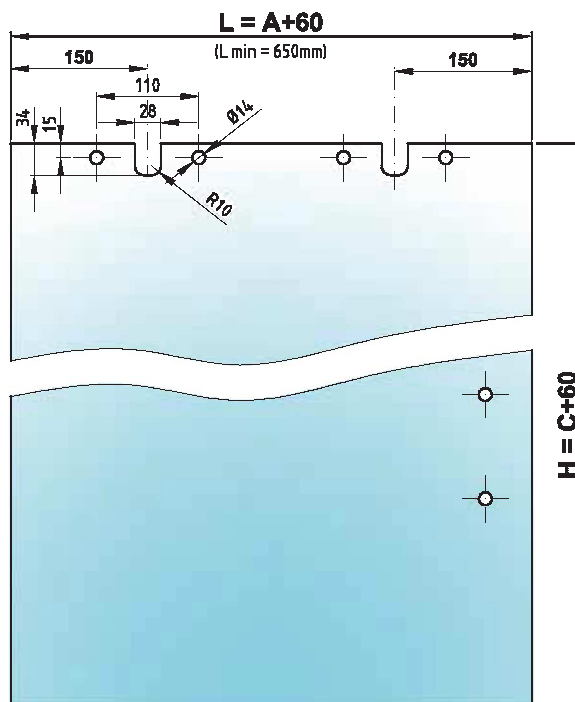

Sistema Flo - Sistema Flo - Flo system - Flo System

BF06

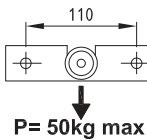
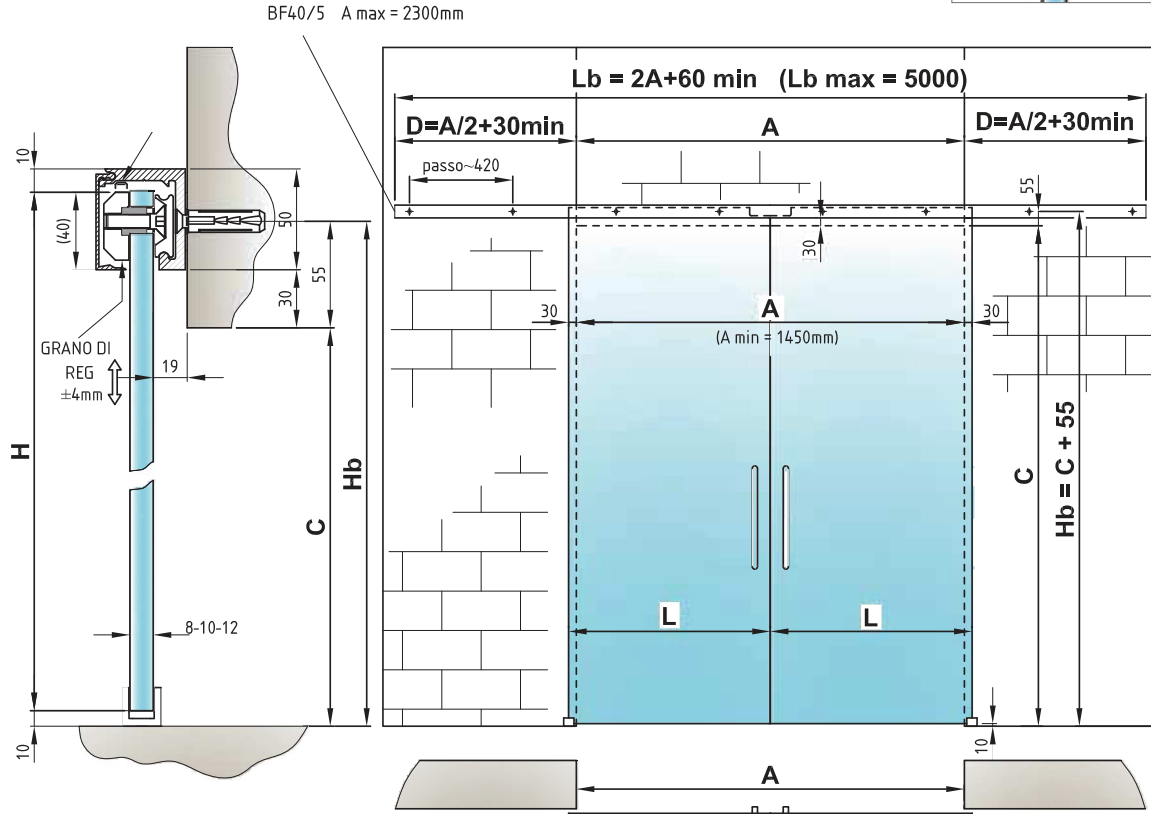
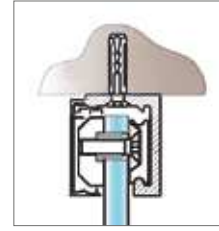

x 2 (100 Kg max)
Applicazioni P>100 Kg e A>2000 su richiesta
Application P>100 Kg or A>2000mm upon request

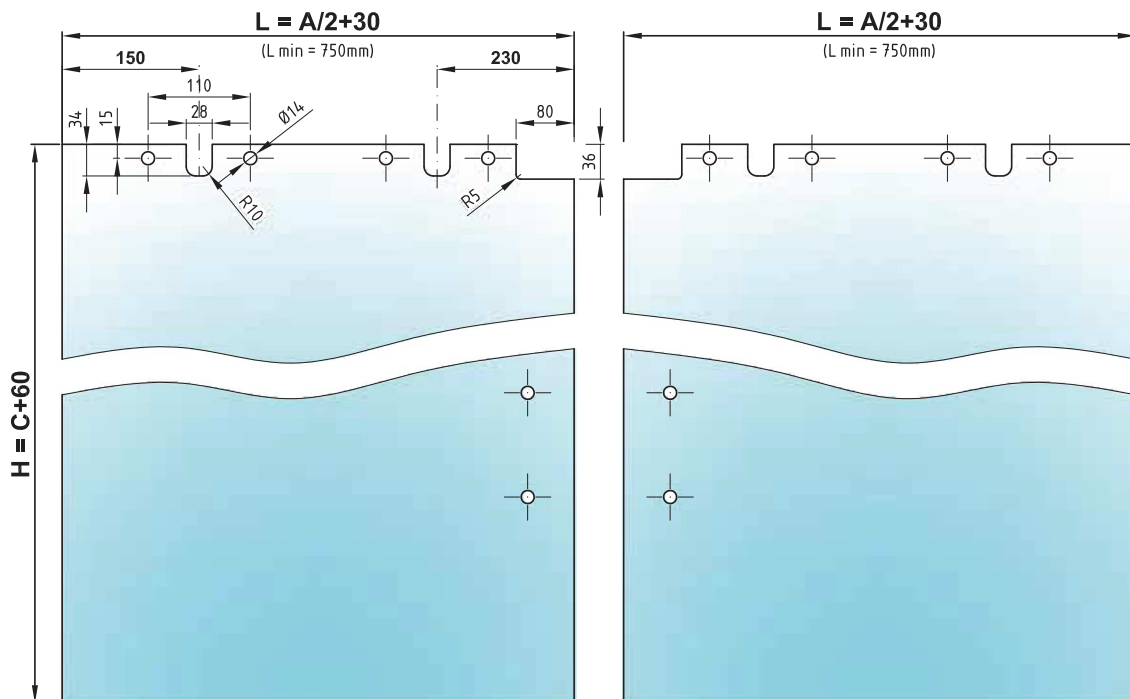

BF07

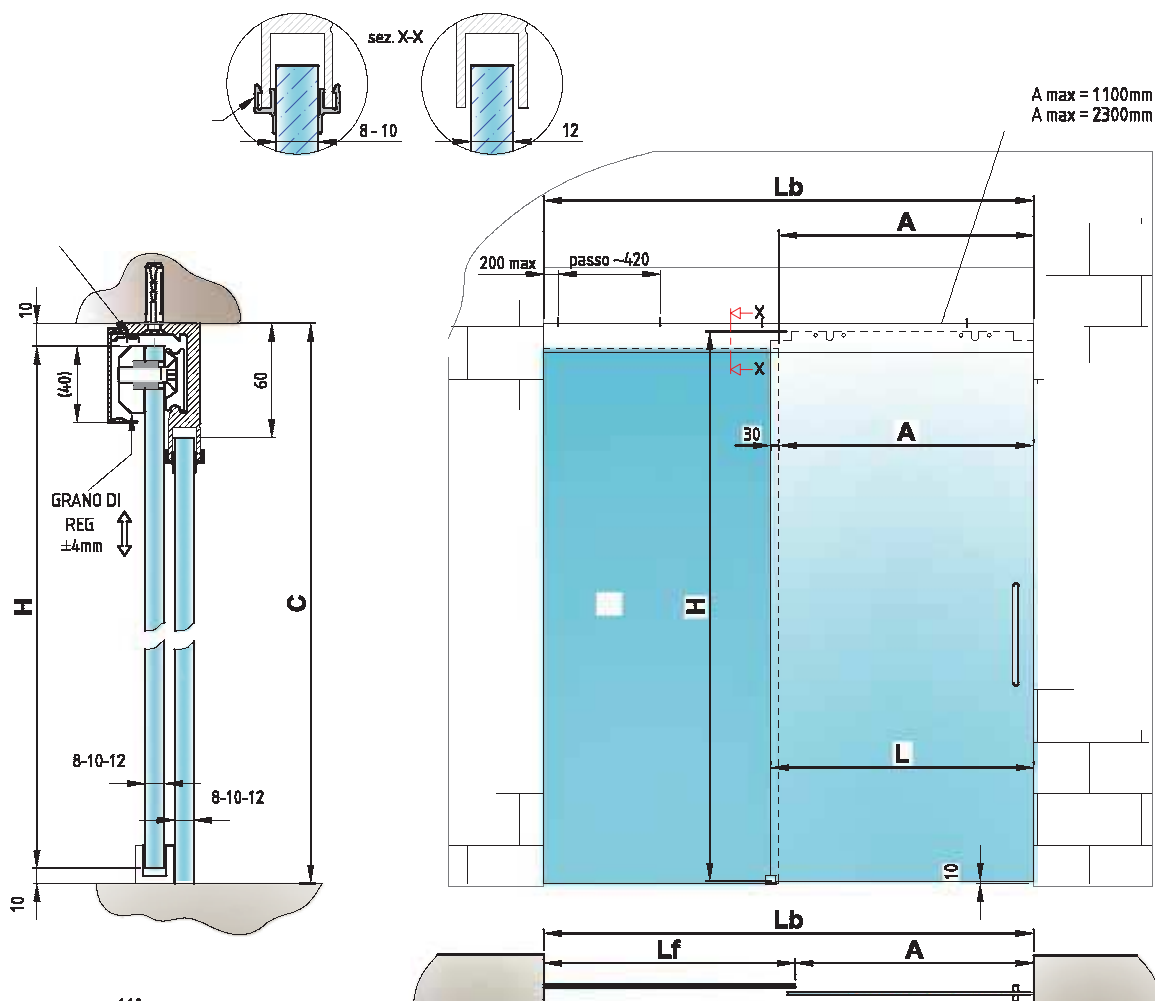

A max = 1100mm
A max = 2300mm

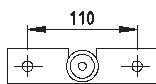

x 2 (100 Kg max)
x 3 (150 Kg max o A>1500mm)

P= 50kg max

Applicazioni fuori standard su richiesta
Not standard application upon request

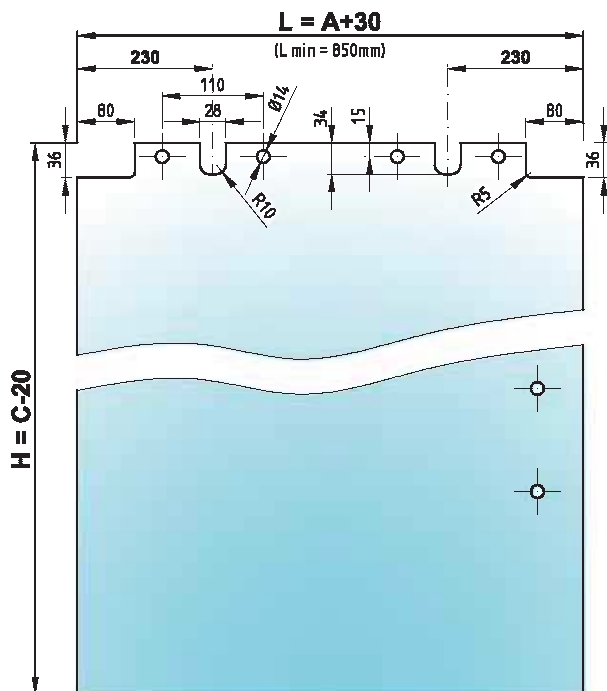

BF08

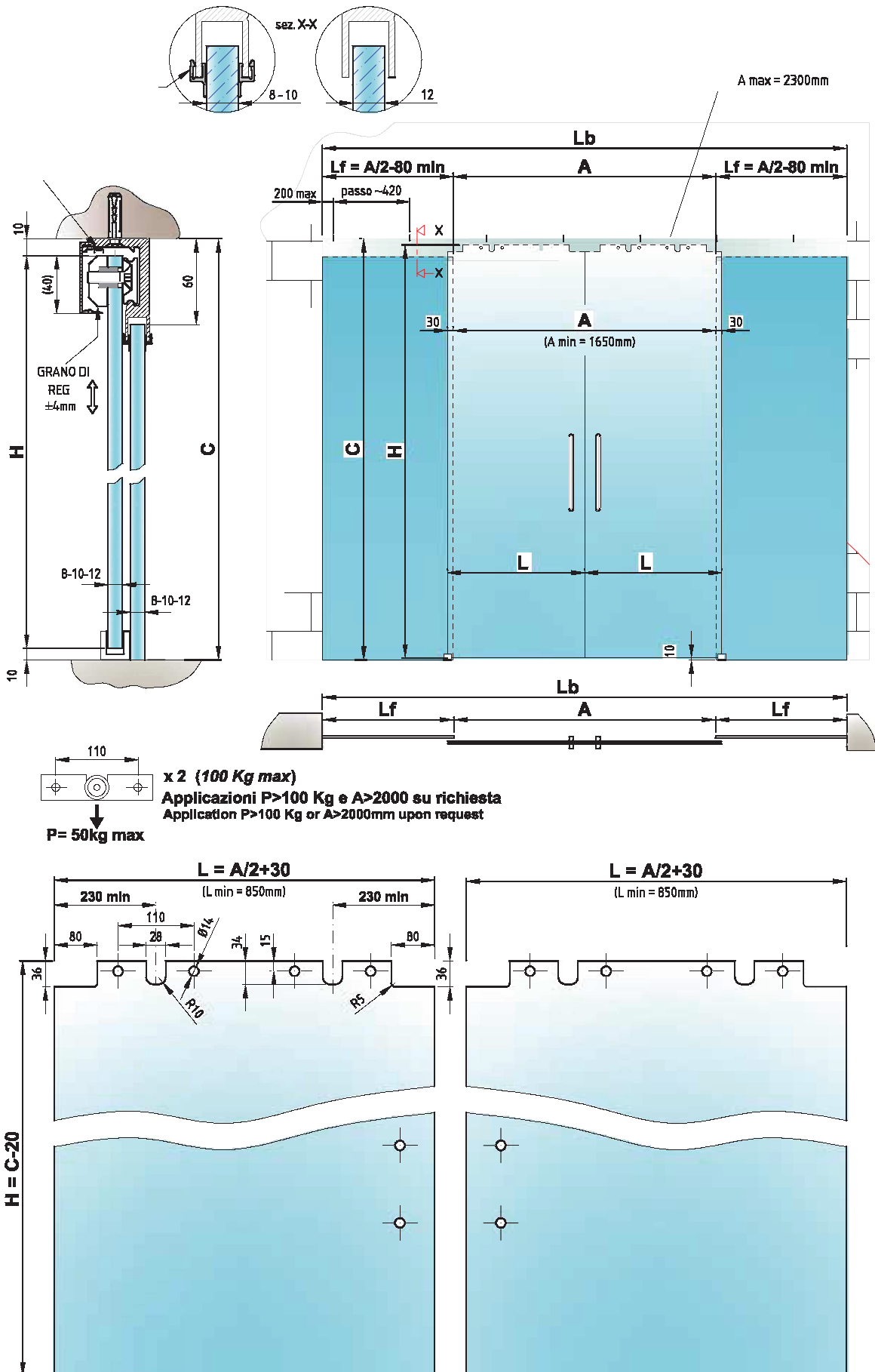

Sistema Flo - Sistema Flo - Flo system - Flo System